

CML 18 ATEX 3377U
 II 2G D
 Ex 60079-30-1 IIC Gb
 Ex 60079-30-1 IIIC Db
 Ts=-40°C to +90°C

SK / HTS1FAR / MED / P & B

LongLine LLR Cable
(supplied separately)

For splice connection
of HTS1FAR 12.6 and 19.6
sized heating cables.



Made in the UK

(Mar 23)

ITEM	DESCRIPTION	QTY	COMMENTS
1	Connector	1	14mm Ø
2	Enclosure	1	33mm Ø
3	Gland	2	P - M25 for HTS1FAR 12.6 & 19.6 B - M20 for HTS1FAR 12.6 & 19.6
4	Silicone Sealant	100ml	
5	Constant force spring	2	
6	Earth Braid & Coloured Sleeve	1	
7	Self-amalgamating tape	1	

Tools required



→ Prepare Heater Cable

Use tools: 2 5 6 8

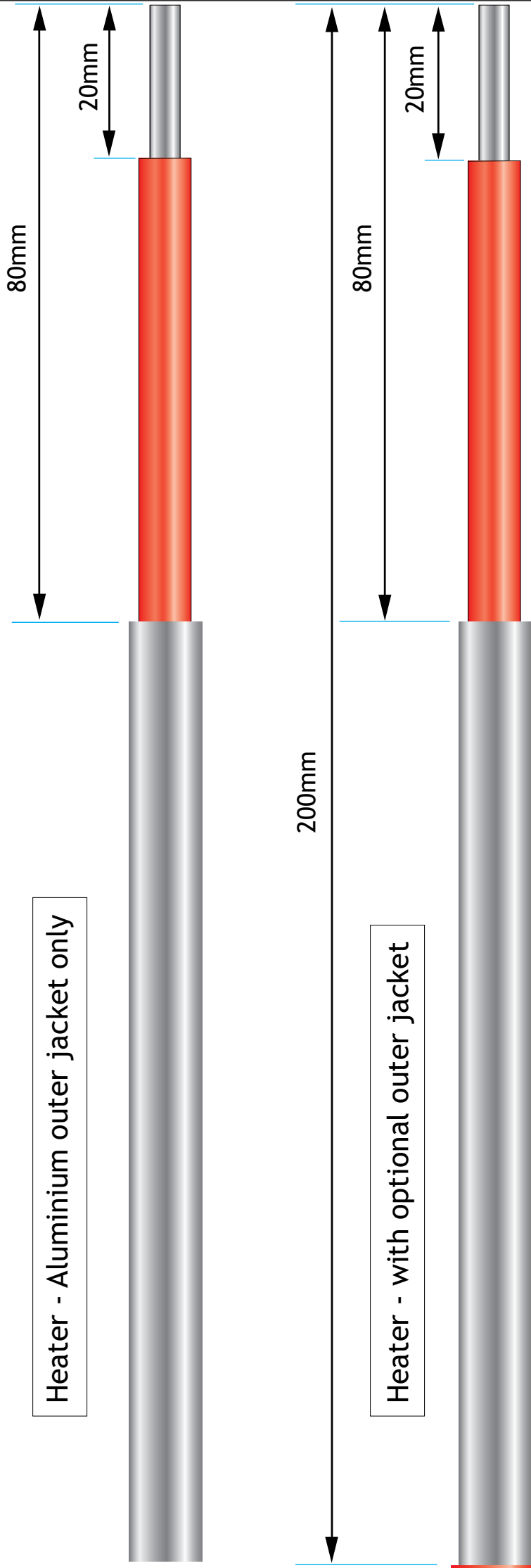

Assembly of Termination

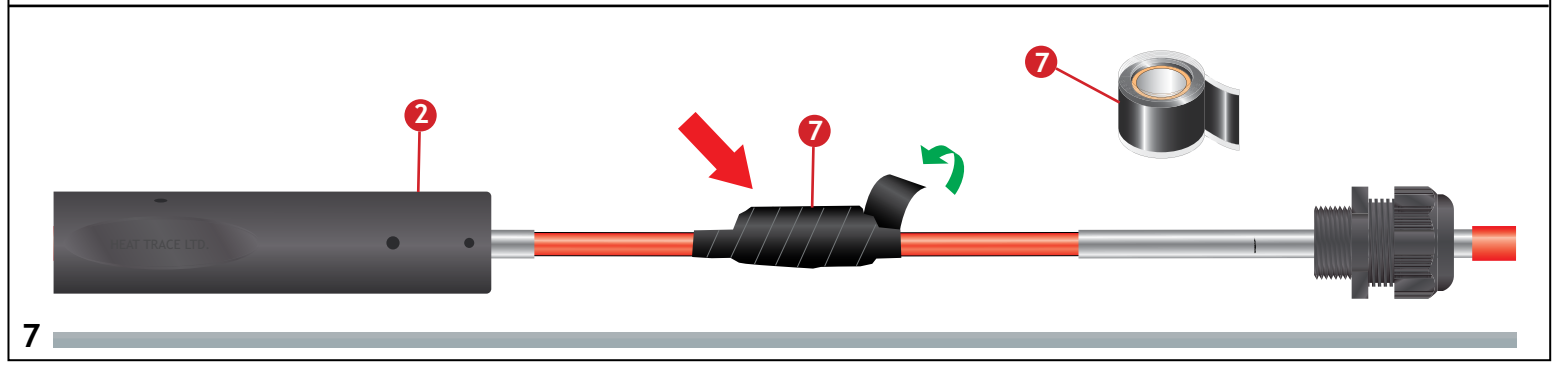
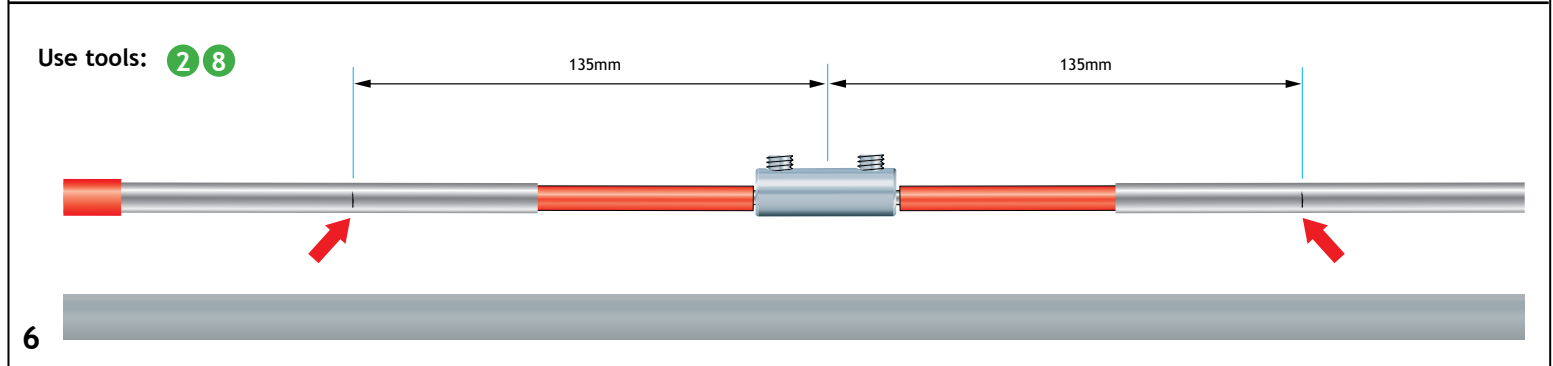
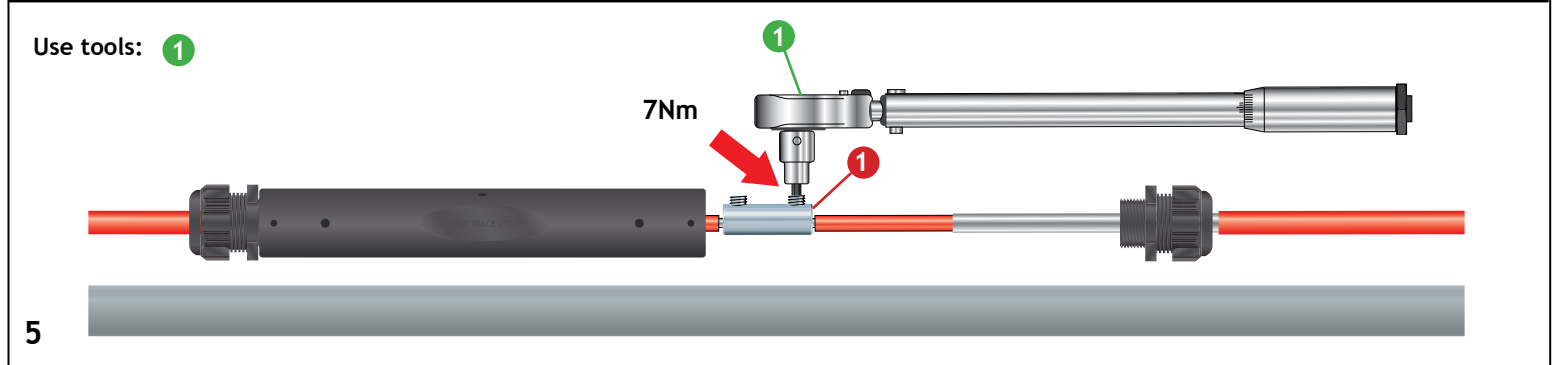
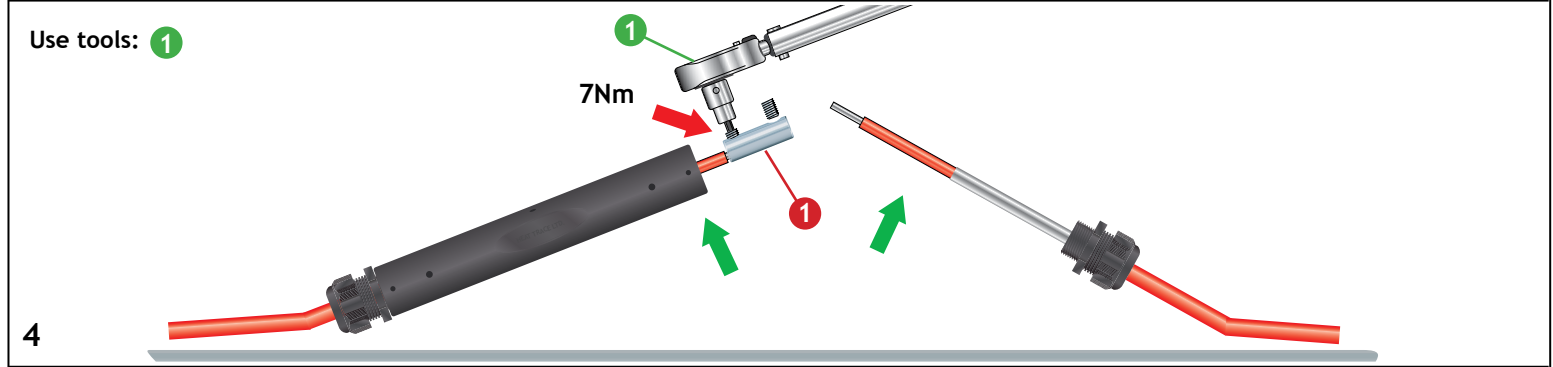
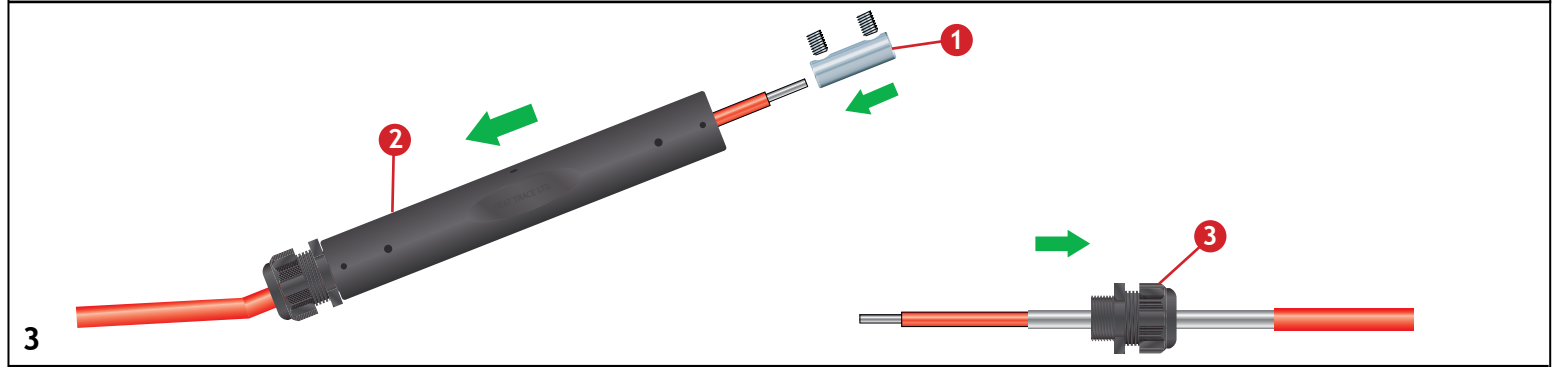
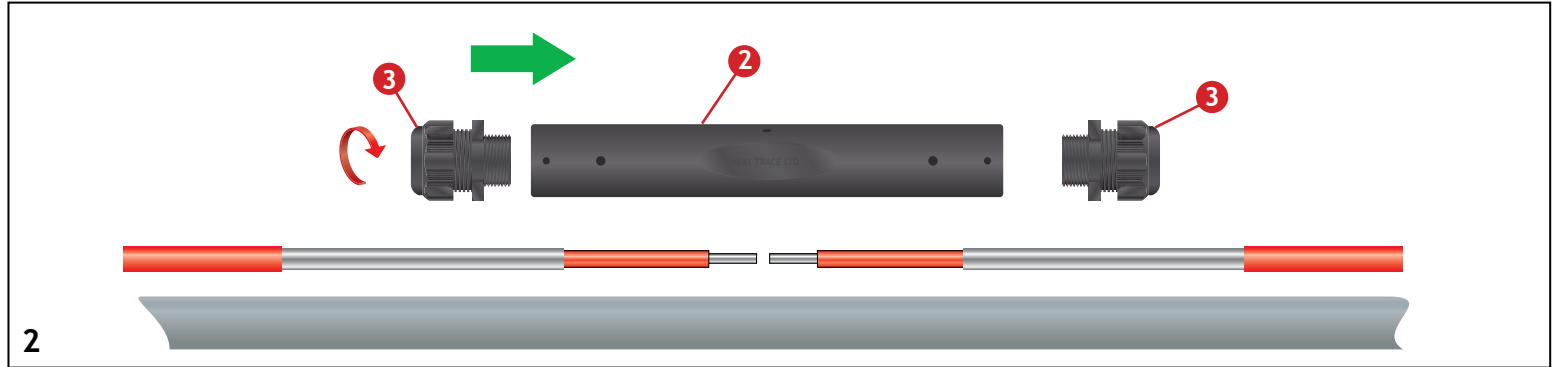

Assembly of Termination

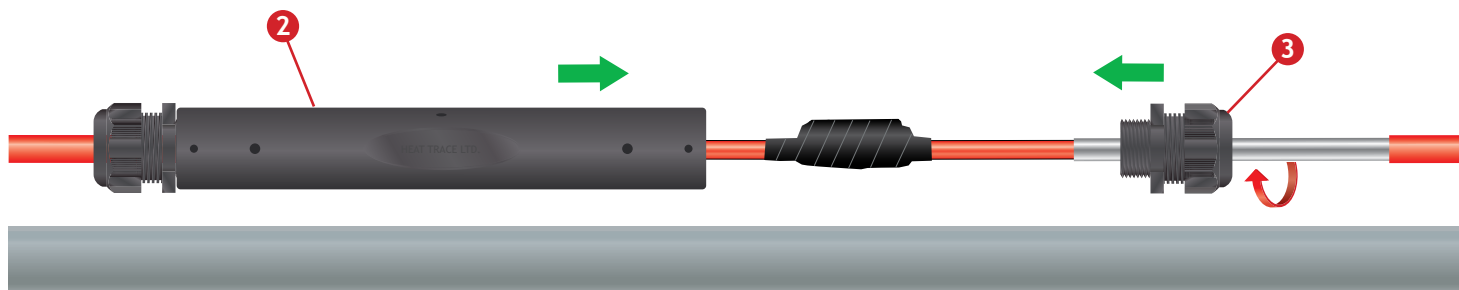

Use tools: 4

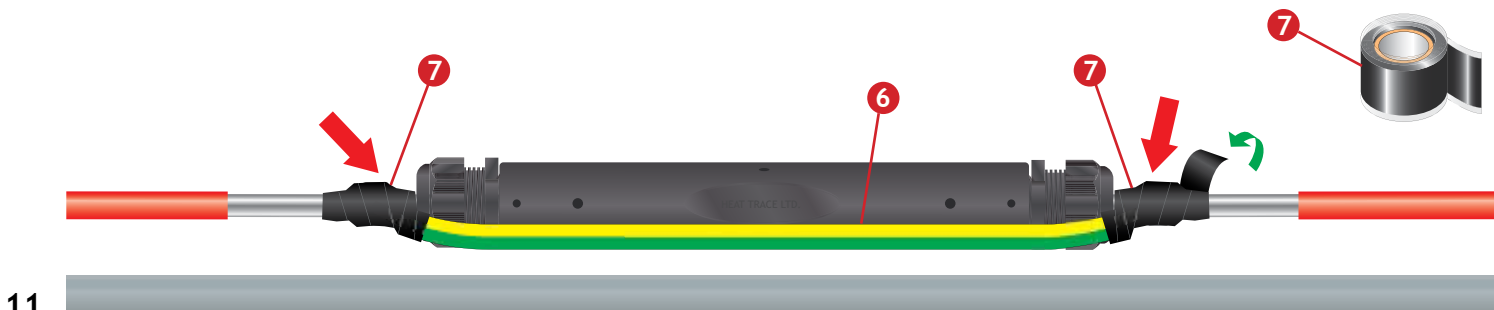
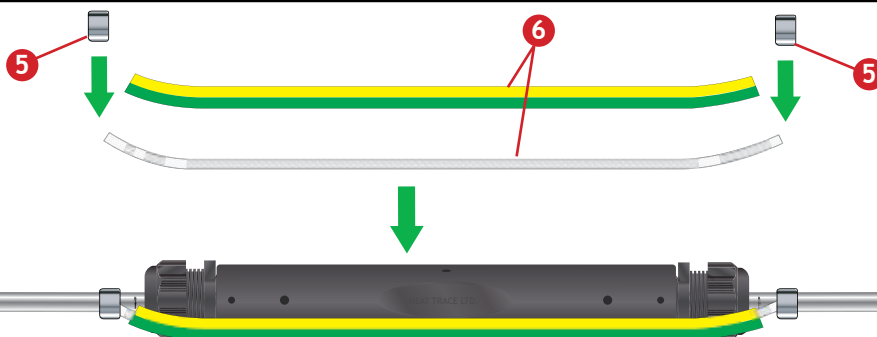
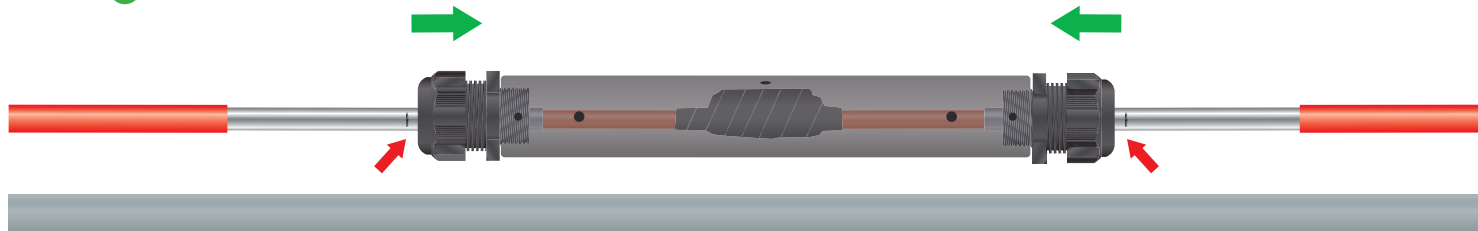

Use tools: 3 7

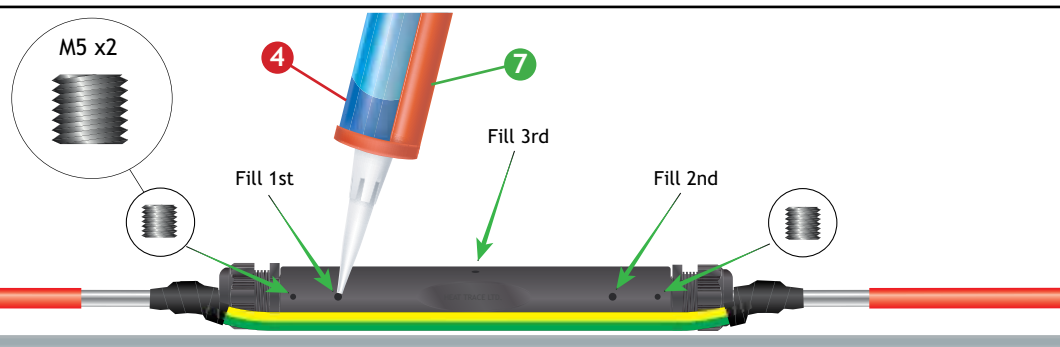

Use tools: 3

