

Local Isolator with Front Operated Switch (R160/LS/F, R200/LS/F)

Isolator Switch for electrical
Heat Tracing circuits.

R Series Solution

- Available for use in safe and hazardous areas.
- Enclosures suitable for Gas Group IIA, IIB and IIC.
- Ingress Protection IP66.
- Full range of accessories and termination kits available.
- Power cable termination through terminals.

INTRODUCTION

As part of our commitment to innovation in the industry, Heat Trace Ltd is offering a customised Exd solution.

The Isolator Switch can be provided in sizes, R160 (160mm Dia) and R200 (200mm Dia) which can be configured/customised based on your requirements.

The two pole isolator switch is used to switch off the electrical heat tracing circuit locally in the field. It also has a facility to padlock the switch in the off position to restrict any third party interference during circuit maintenance.

As standard, the enclosure is made of high grade, cast aluminium and painted with RAL 7035 paint. Other options of material for the construction of the enclosure, and paint shade are available on request.



The Heat Tracing Authority™

SPECIFICATION

ENCLOSURE:

Material:	Standard Copper Free Aluminium
Paint shade:	RAL 7035, light grey
Protection:	EX (db) - IP66
Rated voltage:	1.1kV AC / DC
Area suitability:	Zone 1 / Zone 2, IIA / IIB / IIC
Cable entries:	3 off (2 for power cables, 1 for external switch)
Isolator rating:	2P-25A/40A/63A
External Operator:	On/Off external switch
Earthing:	Internal and external earthing
Number of Terminals:	6 off (2 Live, 2 Neutral & 2 Earth)

APPROVAL DETAILS:

ATEX	-	CML 23ATEX1502X
IECEX	-	IECEX CML 23.0177X
UKCA	-	CML 23UKEX1503X

EQUIPMENT MARKING:

IECEX:

Gas: Ex db IIC T6/T5 Gb
Dust: Ex tb IIIC T85°C/T100°C Db
-60°C or -20°C <Ta< +45°C / +60°C /
+75°C

ATEX/UKCA:

Gas: Ⓢ II 2 G D Ex db IIC T6/T5 Gb
Dust: Ⓢ II 2 G D Ex tb IIIC T85°C/T100°C Db
-60°C or -20°C <Ta< 45°C / +60°C /
+75°C

STANDARD KIT CONTENT:

- Junction box with specified entries fitted with Din rail, terminal & accessories (terminal, end plate, stopper, shorting link, terminal marker whichever is applicable).
- 2P Isolator switch with external operator and On/off position indication.
- 2 off stainless steel earthing studs.
- O ring, grub screw, allen key for grub screw.
- Stainless steel certification plate.
- Stainless steel tag plate.
- 2 off M8x12 Stainless nut, bolt and washer sets for mounting.
- Cable entry marking sticker.
- External earthing stud is fitted with PVC sleeved copper lug.
- Earthing sticker.
- Instruction manual.

SAFE USE:

Only certified cable glands & accessories of required Ex protection shall be used.

Each entry shall have no more than one thread adaptor. A stopping plug shall not be used with a thread adaptor.

If holes or unused cable entry are left open, explosion protection can no longer be guaranteed.

Close open holes using stopping plugs approved for required type of protection.

MORE CUSTOMISATION ON REQUEST:

Please ask for price and delivery for the options below:

- Paint shade other than RAL 7035 can be offered on request.
- Enclosure stainless steel, cast iron.
- Installation accessories, cable gland for RTD cable, pipe mounting support bracket & pipe straps.
- Alternate make or type of terminals.

HEAT TRACING JUNCTION BOX WITH THERMOSTAT LIGHT INDICATION

PART NO. : R160/LS/F*

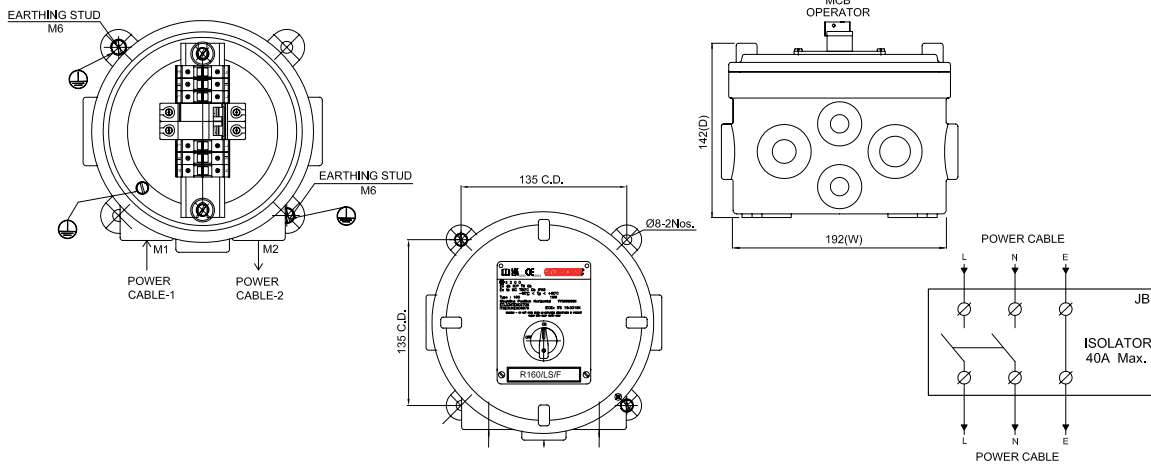

S/N	Description	Part number*	Power cable size (mm ²)	Tightening torque (Nm)	Entry size for** Power cable M1/M2	MCB Rating (Amp)
1		R160/LS/F/4/25A	3C x 4	0.5	M20	25A
2		R160/LS/F/6/25A	3C x 6	0.8	M20	25A
3	Local isolator switch	R160/LS/F/10/25A	3C x10	1.2	M25	25A
4	with front operator	R160/LS/F/10/40A	3C x10	1.2	M25	40A
5		R160/LS/F/16/40A	3C x16	1.2	M25	40A

PART NO. : R200/LS/F*

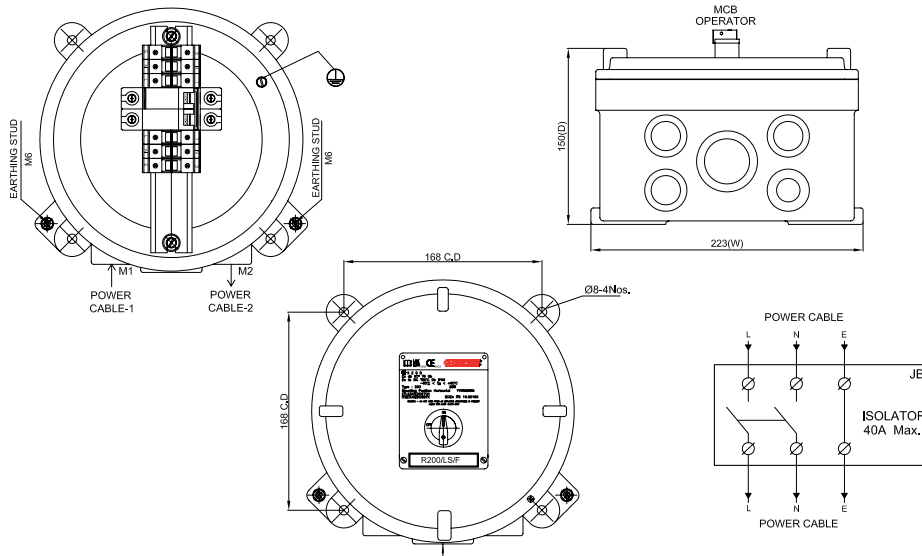

S/N	Description	Part number*	Power cable size (mm ²)	Tightening torque (Nm)	Entry size for** Power cable M1/M2	MCB Rating (Amp)
1	Local isolator switch	R200/LS/S/25/25A	3C x 25	2	M32	25A
2	with front operator	R200/LS/S/25/40A	3C x 25	2	M32	40A

** Equivalent NPT entries can be provided on request.

Note: 1) All dimensions are in mm with tolerance of ±5%.

2) External earthing stud is fitted with PVC sleeved copper lug.



Heat Trace Ltd, Mere's Edge, Chester Road, Helsby, Frodsham, Cheshire, WA6 0DJ, England.

Tel: +44 (0)1928 726451

www.heat-trace.com

Email: info@heat-trace.com

The information given herein, including drawings, illustrations and schematics are intended for illustration purposes only. Heat Trace Ltd makes no warranties as to its accuracy or completeness and disclaims any liability in connection with its use. Users of Heat Trace Ltd products should make their own evaluation to determine the suitability of each such product for specific applications. In no way will Heat Trace Ltd be liable for any damages arising out of the misuse, resale or use of the product.