



Handbook of Industrial Electric Heat Tracing

IMPORTANT NOTICE!

Please note that this Handbook is currently being modified and updated as our product range has been improved and upgraded. This is in line with our policy of continual development and improvement.

Some of the technical data relating to product operating parameters will be changed.

We therefore request that, when carrying out system designs and choosing products, you should refer directly to each product's individual Technical Data Sheet that can be downloaded from the Heat Trace Limited website at:

www.heat-trace.com

If you have any questions, or need advice, please contact our Engineering Department at our Corporate Headquarters engineeringandelectronics@heat-trace.com

Thank you for your cooperation - Marketing Department

- System Design
- Product Selection
- Installation
- Commissioning
- Maintenance

The **Heat Tracing Authority™**





1 HEAT TRACE LIMITED

- The Innovation Culture – the Past, the Present and the Future **4-5**
- Heat Trace Limited **6-7**

2 INDUSTRIAL HEAT TRACING – An Introduction

- What is it? **8**
- What is its purpose? **8**
- Steam or Electric? **8**
- The Need? **8**
- The System? **8**
- Safe Practice **9**
- Applicable Standards **9**
- Applications **10-11**

3 SYSTEM DESIGN – General

- Objective – A safe system that works **12-13**
- Considerations in Hazardous Areas **14-17**
- Heating Loads **18-19**
- Temperature control **20**
- Circuit monitoring **21**

4 PRODUCTS AND PRODUCT SELECTION

- Heating Cables – Generic types **22-25**
- Heating Cables – Selection Guide **26-27**
- Typical Long Pipeline Applications **28-29**

- Parallel, self-regulating **30-35**
- Parallel, constant power **36-39**
- Series resistance, Longline **40-43**

- Termination Components **44-45**

- Temperature Control – Selection Guide **46-47**

- Type I Temperature controllers - Maintaining above a minimum point **48-49**
- Type II Temperature controllers - Maintaining within a broad band **50-51**
- Type III Temperature controllers - Maintaining within a narrow band **52-53**

- Circuit Monitoring Equipment **54-55**





INSTALLATIONS 5

- Installation and System Testing
- Commissioning & Documentation
- Maintenance

56-63
64-65
66-67

NOTES 6

- Notes

68-69





The Past, the Present,and the Future

The Past

When Heat Trace Limited was founded in 1974, electric heat tracing was in its infancy – most heat tracing used steam as its heat source at that time.

In the four decades since, electric heat tracing has grown into an industry in its own right. Heat Trace Limited has played a prominent role in its growth throughout as a **Leader in Innovation**.

From the start, Heat Trace developed products and systems meeting Heat Trace’s own corporate objectives of improving:-

**safety,
efficiency,
reliability
and performance.**

The world’s first parallel resistance cut-to-length Heat Tracer heating cable was patented, developed and launched by Heat Trace Limited in 1975. It remains within our product range to this day, bearing testament to the significance of this invention.

Heat Trace Limited were perhaps the first Heat Tracing company to recognise the important link between control technology and the “safety, efficiency, reliability and performance” of heat tracing installations.

The company patented PowerMatch, a self-regulating proportional controller that turns heater power up or down in response to changes in heat losses. Although launched almost 20 years ago, the benefits of ambient proportional control to safety and efficiency have only recently been recognised on a global basis.

Innovation-led technology resulted in Heat Trace Limited becoming the industry’s technical leader...

The Heat Tracing Authority™

The Present

Heat Trace’s **Innovation Culture** has culminated in its position as the Technology Leader within our Industry today. This position is demonstrated by:-

1. The largest and best range of self-regulating heating cables

- Highest continuous ‘maintain’ temperature (200°C)
- Highest continuous ‘withstand’ temperature (300°C)
- Widest voltage range (12 to 1000V)
- All inherently temperature-safe (IT-S)

Heat Trace’s range of self-regulating heating cables cater for most heat tracing applications

2. The highest temperature cut-to-length Heat Tracer in the world.

Heat Trace’s patented mineral insulated, metal sheathed, type AHT heating cable can withstand 500°C continuously, and deliver up to 200W/m.

The AHT tracer can cater for virtually all applications outside the capability of the self-regulating tracer range.

3. EVOLUTION - the world’s most advanced heat tracing Design Tool (See section 6).

Additionally, Heat Trace’s range of electronic control and monitoring equipment extends from simple thermostats to microprocessor controls capable of integrating into overall plant SCADA and DCS systems.

Today, Heat Trace Limited is a global company providing complete heat tracing solutions. In addition to systems manufacture, services include consultancy, system design, commissioning, project management and training.

Heat Trace Limited continues to be...

The Heat Tracing Authority™





The Past, the Present,and the Future

The Future

Heat Trace's emphasis on an **Innovation Culture** has resulted in an extensive and active Research and Development Department, located at the Heat Trace Innovation & Technology Centre near Manchester UK.

In addition to test equipment the Centre has its own specialist pre-production, prototyping and compounding facilities, including polymer, elastomer, mineral and metal continuous extrusion capability.

The Technology Centre is fully equipped to carry out all international standard type testing. In addition, the Centre has a 40ft (12m) x 7ft (2.2m) x 6.5ft (2m) refrigerated cold room facility that allows us to carry out product and systems testing down to -40°C.

At the time that this brochure went to press, Heat Trace Limited had multiple patents/patent applications in the course of development, and an extensive Product Development project list, mainly involving semi-conductive polymer formulations.

These projects will result in many new and unique products and processes over the forthcoming decade ensuring Heat Trace Limited's position as the Technology Leader within its industry sector....



Gravimetric Blending System



Cold Room facility

Heat Trace Limited will remain...

The Heat Tracing Authority™





Heat Trace Limited In the U.K.

Heat Trace Ltd has been manufacturing electrical heating cables in the U.K. since 1974.

The main manufacturing facility and headquarters of the company is at Helsby in the North West of England. This factory houses the main processing equipment for the manufacture of semi-conductive self-regulating heating cables; core compounding, heating matrix extrusion, and other more recognised standard cable making processes. The main item of capital equipment is the Electron Beam Unit – one of only two similar units in the U.K., and one of only a few in Europe.

The Helsby Headquarters handles sales to all countries around the world. Exports account for over 90% of Heat Trace sales.

In addition, the Heat Trace Innovation & Technology Centre is located close to Manchester, only 56 km from the Helsby headquarters. The Bredbury complex has been a Heat Trace owned premises for over 25 years, and constant power heating cables are made here.



Helsby Headquarters



Bredbury Manufacturing Facility



Research & Development Laboratory at Bredbury



Heat Trace Limited



Control Panel for 3m Pipe Test Rig



24 Spindle Braider



Extrusion Temperature Control Unit



3m Pipe Test Rig



Skin Effect Test Rig





INDUSTRIAL HEAT TRACING – An Introduction

Heat Tracing – What is it?

“Heat Tracing (or Trace Heating, or Surface Heating) is the method of applying heat to a body, or to a product (liquid, powder, or gas) contained within a system (pipework, vessel or equipment) for storage or transportation, in order to avoid processing problems or difficulties.”

Heat may be applied, for example, to:-

- **Liquids**
 - to prevent freezing
 - to enable pumping by reducing the viscosity of the liquid
- **Powders**
 - to eliminate condensation from the walls of equipment that could result in ‘clogging’ of the product
- **Gases**
 - to prevent hydration due to a drop in gas pressure across pipework fittings such as valves

Heat Tracing – What is its purpose?

Heat Tracing is usually provided to maintain a product or equipment at a temperature that will prevent processing problems. For example :-

- Above 5°C – to freeze protect water or aqueous solutions
- Above, for example, 50°C – to prevent oil from becoming too viscous to pump
- To maintain surfaces above a dew point temperature below which condensation could form on a surface and potentially create ‘clogging’ of a powder.

Heat Tracing may also be required to raise the temperature of products or equipment from cold to the required maintain temperature. For example :-

- A pipeline is used infrequently to deliver fuel oil from an off-loading berth into a plant area. In such a case, the pipeline and its contents may be raised from the ambient temperature to the fuel oil pumping temperature over a period of, for example, 24 hours prior to the delivery of the fuel oil.

Heat Tracing – The Need

Whenever the contents of a pipe or equipment are maintained at a process temperature exceeding the ambient temperature, there will be a flow of heat from the product or equipment through the thermal insulation to the external air, and *the rate of heat loss varies directly with changes in ambient temperature.*

In order to prevent the temperature of the product from falling below its required level, this **variable** heat loss must be compensated for by heat tracing the pipeline or equipment.



Heat Tracing – Steam or Electric?

The energy source for heat tracing is most commonly electricity or steam.

When excess steam is available, it may, incorrectly, be perceived to be ‘free’. But steam tracing is rarely controlled and may typically deliver six times the quantity of heat required to provide freeze protection to a pipe. Additionally, it has high running and maintenance costs due to leaks from steam traps.

In such circumstances, often the most efficient course of action is to use the excess steam to generate electricity, which is then used as the energy source for a controlled and highly efficient electric heat tracing system.

Heat Tracing – The System

An electric heat tracing system often comprises:-

- heating cable(s) together with termination components
- ancillary items such as junction boxes and fixing materials
- temperature control devices (sometimes / optional)
- monitoring / alarm facilities (sometimes / optional)
- power distribution / circuit protection facilities

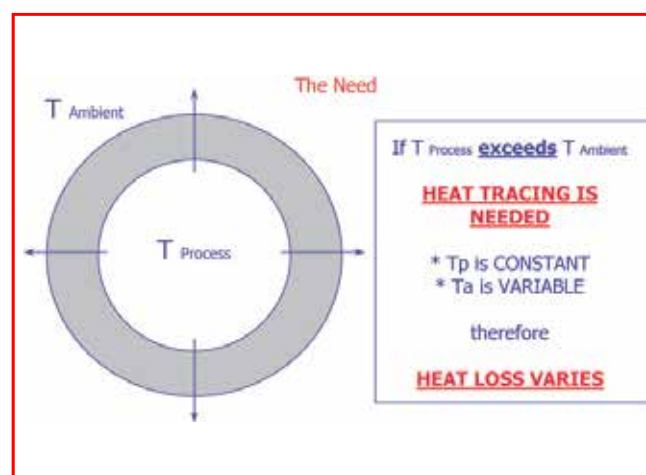



INDUSTRIAL HEAT TRACING – An Introduction

Heat Tracing – Safe Practice

A heat tracing installation should provide the highest appropriate levels of Safety. This is mainly provided for by:-

- ensuring temperature safety
- over-current circuit protection
- earth-leakage protection

This is discussed in more detail in SECTION 3 – System Design.

Heat Tracing – Applicable Standards

Electric heat tracing is governed by a number of International and National Standards covering both Safe and Hazardous industrial locations. A list of the most important standards, to which many of Heat Trace's products are approved, are shown in the table below

Although Heat Trace can design and supply equipment approved to most national standards, for purposes of clarity, this document focuses on the standards developed especially for Electric heat tracing:-

- IEC62395 - Electric Heat Tracing for Safe Industrial locations or commercial applications, and
- IEC60079-30 - Electric Heat Tracing for Hazardous locations (formerly IEC62086)



This is because these are the most recent publications, and are truly international. The International Electro-technical Commission comprises most industrialised nations from all continents.

The trace heating industry is co-operating to produce harmonised standards. Currently the hazardous location part of IEEE515 and IEC60079 are being directly aligned into a single dual-logo standard.

| Industrial Locations | Hazardous Locations |
|--|---|
| <p style="text-align: center;">IEC 62395-1, (EN 62395-1) Electrical resistance trace heating systems for industrial and commercial applications - Part 1: General and testing requirements</p> <p style="text-align: center;">IEC 62395-2 Electrical resistance trace heating systems for industrial and commercial applications - Part 2: Application guide for system design, installation and maintenance</p> | <p style="text-align: center;">IEC 60079-30-1 (EN 60079-30-1) Explosive atmospheres - Part 30-1: Electrical resistance trace heating - General and testing requirements</p> <p style="text-align: center;">IEC 60079-30-2 (EN 60079-30-2) Explosive atmospheres - Part 30-2: Electrical resistance trace heating - Application guide for design, installation and maintenance</p> |
| <p style="text-align: center;">IEC 60519-10 Safety in electroheat installations - Part 10: Particular requirements for electrical resistance trace heating systems for industrial and commercial applications</p> | |
| <p style="text-align: center;">CAN/CSA-C22.2 No. 130-03 Requirements for electrical resistance heating cables and heating device sets</p> | |
| <p style="text-align: center;">UL 1673 Electric Space Heating Cables</p> | <p style="text-align: center;">UL 515 Parts 3 - 9: Hazardous location requirements</p> |
| <p style="text-align: center;">UL 1588 Roof and gutter de-icing cable units</p> | |
| <p style="text-align: center;">UL 515 Part 1: Commercial and industrial ordinary locations Part 2: Heat tracing intended for use with fire suppression sprinkler or standpipe systems</p> | |
| <p style="text-align: center;">IEEE Std.515.1 Standard for the Testing, Design, Installation and Maintenance of Electrical Resistance Heat Tracing for Commercial Applications</p> | <p style="text-align: center;">IEEE Std.515 Standard for the Testing, Design, Installation, and Maintenance of Electrical Resistance Trace Heating for Industrial Applications</p> |



Typical Applications / market sectors

Bakery equipment

- heating fuel oil pipes to the ovens
- bread fat heating
- anti-condensation for flour storage
- heating glucose and sucrose products

Brewing

- heating malt, glucose and water pipes and tanks
- fuel oil systems

Chemicals

- heating numerous viscous liquids and/or gases
- research projects
- many refinery applications

Ceramic industry

- heating fuel oil
- paint and varnish heating

Chocolate and sweets

- heating chocolate in pipes and vats
- heating chocolate in road tankers
- heating liquid sugars
- heating cocoa butter and fats

Detergent and soaps

- heating various viscous liquids
- general frost protection

Medicine

- many applications especially in the pharmaceutical industry where waxes, tallowes and stearates are used.

Non-ferrous metal industries

- fuel oil heating and frost protection
- Oil industry
- fuel oil heating
- lubrication oil heating
- grease line heating
- oil additives heating
- many refinery processes require tracing

Drying and cleaning

- heating fuel oil
- dyestuffs manufacture

Electric motors

- curing glass-fibre banding tape
- heating commutators during manufacture
- anti-condensation heating

Electric transformers

- curing glass-fibre banding tapes
- drying out oil-filled transformers
- frost protection of water-filled transformers



Tank base heating



Pipe tracing



Internal pipe tracing



Typical Applications / market sectors



Final Settlement Tank de-icing

Food processing

- heating many food process materials, eg malt, sugars, molasses, sauces, honeys, jams,
- Chocolates, waxes, fats, cooking oils
- keeping powdered food dry
- heating storage tanks
- tracing refrigeration rooms

Fertiliser industry

- tracing liquids used in manufacturing inorganic fertiliser

Power generation stations

- boron water
- carbon dioxide
- fuel oil
- caustic solutions
- instrument lines
- frost protection
- pre-heating steam lines to prevent stress
- Precipitator - fly ash hoppers and silos
- flue gas desulphurisation processes, i.e. frost protection and liquid sulphur temperature maintenance



High Temperature Tank heating

Road construction

- heating asphalt (bituminous tar) and pitch in road stone plants
- fuel oil
- frost protection of sand and aggregate in storage hoppers

Iron and steel

- fuel oil systems
- frost protection
- grease pipelines
- hopper heating

Printing

- inks and dyes during manufacture and storage

Plastics industry

- curing thermosetting resins
- accelerated curing of glass fibre

Paints

- paints and varnishes during manufacture and in paint spray applications

Refrigeration

- heating drain lines and drip trays
- heating refrigerator doors
- anti-frost heave of concrete floors

Rubber

- curing rubber sections and fabrications

Sprinkler & fire system manufacture

- frost protection of water-filled lines

Tar distilleries

- heating bituminous materials
- heating road tankers



Buried pipeline tracing



Objective - a Safe system that works

A heat tracing installation should provide the highest appropriate levels of Safety. This is mainly provided by:-

- ensuring temperature safety
- over-current circuit protection
- earth-leakage protection

Temperature safety is ensured by preventing the surface of the heat tracer from exceeding the limiting temperature. This limiting temperature may be the maximum rating of the tracer itself, or, for example, the Temperature Classification where the installation is within a hazardous area.

● Ensuring temperature safety

Temperature safety may be provided in a number of ways. The choice open to a specifier, in descending order of preference are:-

- Inherently temperature-safe heat tracers.

Many self-regulating tracers are inherently temperature-safe, their power output reducing with rising temperature such that limiting temperatures e.g. Temperature Classification or temperature withstand of the heater, cannot be exceeded due to the heat produced by the tracer. **Inherently temperature-safe heat tracers therefore provide the highest level of temperature safety.**

- Stabilised Design

Here, a calculation is made to ensure that, under the worst case conditions, a tracer always operates at below the limiting temperature, without the need for external temperature control. Where inherently temperature-safe heat tracers are not available, stabilised design provides the favoured form of temperature safety.

Stabilised design calculations are complex and should only be undertaken by persons suitably skilled. Heat Trace's Evolution software is able to automatically confirm whether a design is temperature-safe. When it is not, the designer has the choice of selecting tracers having a lower power output or opting for a less safe temperature controlled system.

- Temperature control

Where a stabilised design cannot be assured, it is then necessary to employ temperature control. Here the safety of the system is reliant on the correct functioning of the controller and the correct location and operation of the temperature sensor. **This is therefore the least safe option.**

Specifiers should guard against being offered such designs, which may have capital benefits but with attendant safety risks.

Inherent Temperature Safety - Definition

“The inherent ability to self-regulate at a temperature level below the maximum product rating and withstand temperature of the insulating materials, without the use of temperature control.”

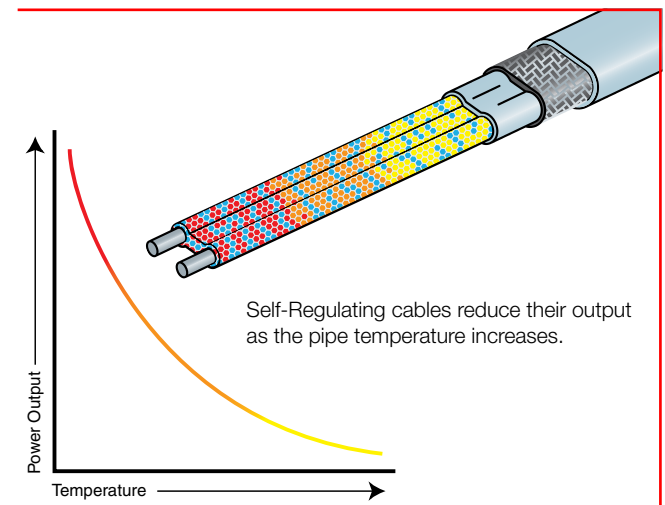

Temperature Control Report

| Pipe Group 1 | | | | | | | | | | Sample Sample Errors | | |
|--------------|------------------|--------------|-------|-------------|-----------------|-------------------|--------------------|---------------|---------------|----------------------|---------------|---------------|
| Line No. | Heater Substrate | Power Output | Class | Temp. Class | Max. Temp. (°C) | Design Temp. (°C) | Control Temp. (°C) | Temp. Control | Temp. Control | Temp. Control | Temp. Control | Temp. Control |
| 5 | 45FSU2-NF | ✓ | | | 15 | 150 | 0 | 200 | 200 | 125 | ✓ | X |
| | | | | | 15 | 150 | 0 | 120 | 200 | 74 | ✓ | X |
| | | | | | 15 | 150 | 0 | 120 | 200 | 76 | ✓ | X |
| | | | | | 15 | 150 | 0 | 120 | 200 | 76 | ✓ | X |

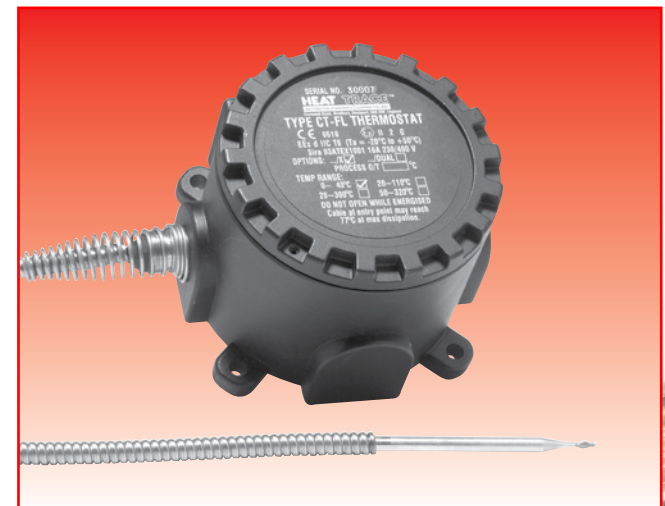



Objective - a Safe system that works

● Circuit Over-current Protection

Each heating circuit should be provided with over-current protection. Maximum safety is provided by a circuit breaker having a rating close to the operating current of the circuit.

Some self-regulating heat tracers exhibit a high in-rush current on start up from cold and require the use of a highly rated circuit breaker with a delayed breaker action. This reduces the level of safety provided.

Safety is maximised when Heat Trace Limited self-regulating heat tracers are specified and circuits are designed to incorporate the patented SSD SoftStart device. The SSD reduces in-rush currents by up to 50% and allows the use of circuit breakers having lower ratings more closely matched to the operating current.

● Circuit Earth Leakage Protection

Each heating circuit should be provided with earth leakage protection.

The residual current device should normally have a sensitivity of 30mA and operate within 30ms. Exceptionally, for example where long heating circuits apply, it may be necessary to decrease the sensitivity level to avoid 'nuisance' tripping.



RCBO Earth leakage circuit breaker





Considerations in Hazardous Areas

Design and equipment selection for use in hazardous areas will be influenced by:-

- the area classification
- the gas (or dust) group
- the temperature classification and equipment selected providing an appropriate type of protection

As stated above, this document focuses on the international standards developed especially for electric heat tracing, IEC62395 – for Safe Industrial locations and IEC60079-30 – for Hazardous locations.

Area Classification

The probability of explosive conditions being present is defined by zone classification

- **Zone 0** may have explosive gas-air mixtures present continuously or for long periods. Heat tracing is rarely, if ever, used in Zone 0 areas.
- **Zone 1** may have explosive gas-air mixtures present in normal operation.
- **Zone 2** may have explosive gas-air mixtures present only under abnormal conditions.

North American hazardous locations are categorised in divisions rather than zones. As stated above IEC60079 and IEE515 are being harmonised as a dual-logo standard. Therefore Heat Trace's product approvals cater for divisions as well as zone locations.

Gas Groups

Gas groups relevant to heat tracing in hazardous locations are:-

- **IIA** – Acetone, benzene, butane, ethane, methane, propane, etc..
- **IIB** - Ethylene, town gas etc..
- **IIC** – Acetylene, hydrogen

| | | Flammable Material Present Continuously | Flammable Material Present Intermittently | Flammable Material Present Abnormally |
|-------------|---------|---|---|---------------------------------------|
| IEC/CENELEC | | Zone 0 (Zone 20 Dust) | Zone 1 (Zone 21 Dust) | Zone 2 (Zone 22 Dust) |
| US | NEC 505 | Zone 0 | Zone 1 | Zone 2 |
| | NEC 500 | Division 1 | | Division 2 |

IEC classification per IEC 79-10
 CENELEC classification per EN 60 079-10
 US classification per ANSI/NFPA 70 National Electric Code (NEC) Article 500 or Article 505

IEC / CENELEC

Example of hazardous area zones - Petrol Station Forecourt & Garage

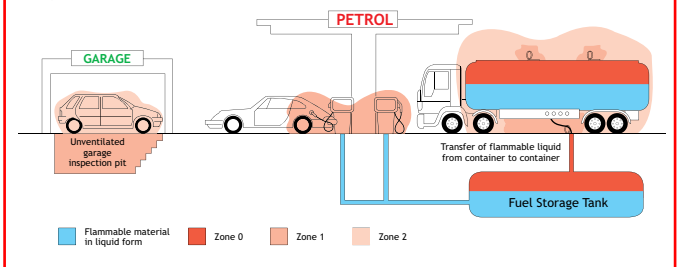

NORTH AMERICAN APPROVAL MARKING

| NORTH AMERICAN / EUROPEAN AREA CLASSIFICATION EQUIVALENTS - GAS | | | |
|---|---|---|---------------------------------------|
| | Flammable Material Present Continuously | Flammable Material Present Intermittently | Flammable Material Present Abnormally |
| IEC / EU | Zone 0 | Zone 1 | Zone 2 |
| US NEC 505 | Zone 0 | Zone 1 | Zone 2 |
| US NEC 500 | Division 1 | | Division 2 |
| CA CEC Section 18 | Zone 0 | Zone 1 | Zone 2 |
| CEC Annex | Division 1 | | Division 2 |

IEC classification per IEC 60079-10 IEC classification per EN 60079-10
 US classification per ANSI / NFPA 70 National Electrical Code (NEC) Article 505
 CA classification per CSA C22.1 Canadian Electrical Code (CEC) Section 18 or Annex J

| NORTH AMERICAN / EUROPEAN EQUIPMENT GROUPING EQUIVALENTS - GAS | | |
|--|--|----------------------------------|
| | US (NEC 505) CA (CEC Section 18) EU IEC | US (NEC 500) CA (CEC Annex J) |
| Typical Gas | | |
| Acetylene | Group IIC | Class I / Group A |
| Hydrogen | (Group IIB + H ²) | Class I / Group B |
| Ethylene | Group IIB | Class I / Group C |
| Propane | Group IIA | Class I / Group D |
| Methane | Group I* | Mining* |

*Not within scope of NEC. Under jurisdiction of MSHA. Not within scope of CEC.

| NORTH AMERICAN / EUROPEAN AREA CLASSIFICATION EQUIVALENTS - DUST | | | |
|--|---------------------------------------|---|-------------------------------------|
| | Combustible Dust Present Continuously | Combustible Dust Present Intermittently | Combustible Dust Present Abnormally |
| IEC / EU | Zone 20 | Zone 21 | Zone 22 |
| US NEC 506 | Zone 20 | Zone 21 | Zone 22 |
| US NEC 500 | Division 1 | | Division 2 |
| CA CEC Section 18 | Division 1 | | Division 2 |

US area classification per ANSI / NFPA 70 National Electrical Code (NEC) Article 500 or 506
 CA area classification per CSA C22.1 Canadian Electrical Code (CEC) Section 18
 EU area classification per EN 61241-10 IEC area classification per IEC 61241-10

| NORTH AMERICAN / EUROPEAN EQUIPMENT GROUPING EQUIVALENTS - DUST | | | | |
|---|-------------------------------|--------------|-------------------------------|-------------------------------------|
| Typical Material | EU (60079-0) IEC (60079-0) | US (NEC 506) | IEC (61241-0) EU (61241-0) | US (NEC 500) CA (CEC Section 18) |
| Metal dusts | IIIC | N/A | D | Class II, Group E |
| Carbonaceous dusts | IIIB | D | D | Class II, Group F |
| Non-conductive dusts | IIIB | D | D | Class II, Group G |
| Fibres and flyings | IIIA | D | D | Class III |





Considerations in Hazardous Areas

Temperature Classification

The maximum surface temperature of the heater must be kept below the auto ignition temperature of the explosive gas or vapour mixtures which could be present. The classifications are:-

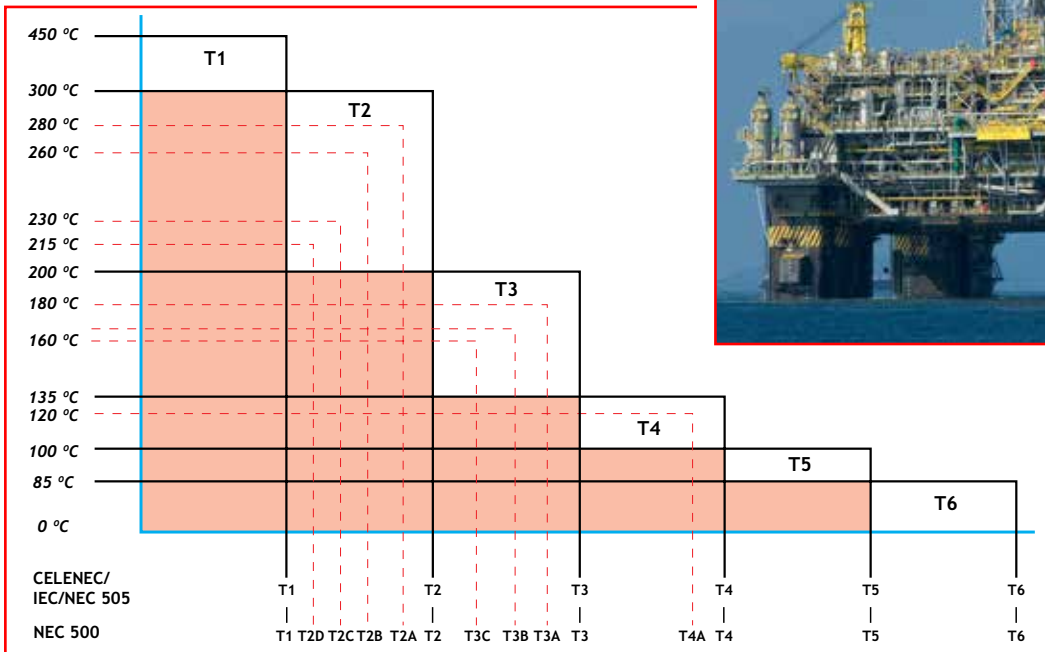

In reality, most gases encountered will have an ignition temperature of T1 or T2. However, it will be recognised that the lower the operating temperature of the heater, the safer the system will be.

For this reason, self-regulating heaters which are inherently temperature-safe should be the preferred safety option. When this is not possible, a calculated stabilised design is preferable to a system that relies on temperature controls for the safety of the system.

Types of Protection

As non-sparking devices, most heaters are likely to be approved to the concept 'e' – increased safety (EExe).

Sparking devices such as thermostats or circuit breakers are most commonly approved to the concept 'd' – flameproof or explosion proof (EExd), although concepts 'i' – intrinsic safety (EExi), and 'p' – pressurised apparatus (EExp) are also sometimes appropriate.

Heat Trace uniquely able to provide tracers with a continuous metal extruded jacket. Such products can be provided with an EX'd' certificate, in addition to an Ex'e' certificate.

Sometimes, distribution boards and control panels can be located outside the hazardous area to avoid the need for additional costly protection.

The following is a simplistic method for the calculation of heating loads for pipes and vessels.





Considerations in Hazardous Areas

European Environmental Protection Classification - IP System

The IP rating system for enclosures containing moving and electrical equipment is recognised in most European countries, meeting a number of British and European standards. It is usually quoted as two digits, in the form IP11.

Relevant standards to which this rating system applies include:

BS EN 60529 and IEC 60529

| FIRST NUMERAL | SECOND NUMERAL |
|---|--|
| Protection against solid objects | Protection against water |
| 0 - No special protection | 0 - No special protection |
| 1 - Objects > 50mm diameter (e.g. part of a hand) | 1 - Vertically dripping water |
| 2 - Objects > 12.5 mm diameter (e.g. finger) | 2 - Vertically dripping water when enclosure tilted by 15° |
| 3 - Objects > 2.5 mm diameter (e.g. tool) | 3 - Sprayed water up to 60° from the vertical |
| 4 - Objects > 1.0 mm diameter (e.g. wire) | 4 - Sprayed water from all directions |
| 5 - Dust protected | 5 - Water jets |
| 6 - Dust tight | 6 - Powerful water jets |
| | 7 - Temporary submersion to a depth of 1m |
| | 8 - Extended submersion to a depth > 1m |

IEC Enclosure Ingress Classification

NEMA Equivalents of IP Ratings

The NEMA and IP Ratings (IEC) differ due to the parameters measured and, to some extent, the methods used.

NEMA 250 tests for external environmental conditions such as corrosion, rust, oil and coolants, which are not specified in the IEC standards IEC 60529.

Note: as many of the NEMA standards meet or exceed the equivalent IP ratings, it is incorrect to use this table to determine IP equivalents of NEMA Ratings.

| NEMA ENCLOSURE TYPE No. EQUIVALENT | IEC ENCLOSURE APPROXIMATION |
|---|-----------------------------|
| 2 - Drip tight indoor use | IP11 |
| 3 and 3S - Outdoor weather resistant to rain, sleet, ice and blown dust | IP54 |
| 3R - As 3/3S except dust | IP14 |
| 4 and 4X - Indoor/outdoor rain, ice, splashing and hosed water, blown dust. 4X - Also corrosion | IP56 |
| 5 - Dust tight indoor use | IP52 |
| 6 and 6P - Outdoor/indoor, occasional limited immersion, ice | IP67 |
| 12 and 12K - Indoor, dust/falling/non-corrosive liquid drips | IP52 |
| 13 - Indoor, dust, spraying water, oil and non-corrosive coolant | IP54 |





Considerations in Hazardous Areas

Methods of Protection

| Protection Method | ID. Letter | IEC | CENELEC | CSA (IEC) | CSA (Annex J) | NEC 505 | NEC 500 | AS / NZS |
|---------------------|------------|--------------|-------------|---------------|-------------------|--------------|---------|---------------------------|
| Flameproof | d | IEC 60079-1 | EN 60079-1 | CSA E60079-1 | CSA C22.2 No. 30 | ISA 60079-1 | FM 3618 | AS/NZS60079-1 / AS2380.2 |
| Intrinsic Safety | ia | IEC 60079-11 | EN 60079-11 | CSA E60079-11 | CSA C22.2 No. 157 | ISA 60079-11 | FM 3610 | AS/NZS60079-11 / AS2380.7 |
| Intrinsic Safety | ib | IEC 60079-11 | EN 60079-11 | CSA E60079-11 | CSA C22.2 No. 157 | ISA 60079-11 | FM 3610 | AS/NZS60079-11 / AS2380.7 |
| Pressurisation | p | IEC 60079-2 | EN 60079-2 | CSA E60079-2 | CSA TIL. E13 A | ISA 60079-2 | FM 3620 | AS/NZS60079-2 / AS2380.4 |
| Increased Safety | e | IEC 60079-7 | EN 60079-7 | CSA E60079-7 | - | ISA 60079-7 | FM 3619 | AS/NZS60079-7 / AS2380.6 |
| Oil Immersion | o | IEC 60079-6 | EN 60079-6 | CSA E60079-6 | - | ISA 60079-6 | FM 3621 | AS/NZS60079-6 |
| Encapsulation | m | IEC 60079-18 | EN 60079-18 | CSA E60079-18 | - | ISA 60079-18 | FM 3614 | AS/NZS60079-18 |
| Type 'n' Protection | n | IEC 60079-15 | EN 60079-15 | CSA E60079-15 | CSA C22.2 No. 213 | ISA 60079-15 | - | AS/NZS60079-15 |
| * Ventilation | v | - | - | - | - | - | - | AS 1482 |

| Protection Method | ID. Letter | Type of Protection | Mode of Function | NEC 500 / CEC Annex J Permitted Division | IEC / CENELEC Permitted Zone |
|---------------------|------------|--|---|--|------------------------------|
| Flameproof | d | Explosion is Contained | Enclosure contains internal explosion | Division 2 | Zone 1 or 2 |
| Intrinsic Safety | ia | Sparks are not ignition capable (Safe 2 faults) | I.S. circuits are unable to cause ignition | Division 1 or 2 | Zone 0, 1 or 2 |
| Intrinsic Safety | ib | Sparks are not ignition capable (Safe 1 faults) | I.S. circuits are unable to cause ignition | Division 2 | Zone 1 or 2 |
| Pressurisation | p | Flammable atmosphere is eliminated | Protection by over pressured enclosure | Division 1 or 2 | Zone 1 or 2 |
| Increased Safety | e | Source of ignition eliminated | Electric sparks & high temp. possibilities eliminated | Division 2 | Zone 1 or 2 |
| Oil Immersion | o | Flammable atmosphere is eliminated | Protection by Immersion | Division 1 or 2 | Zone 1 or 2 |
| Encapsulation | m | Flammable atmosphere is eliminated | Encapsulated apparatus | Division 2 | Zone 1 or 2 |
| Type 'n' Protection | n | n Protection includes several methods of ignition protection | Non-Sparking apparatus | Division 2 | Zone 2 |
| * Ventilation | v | Flammable atmosphere is eliminated | Protection by Ventilation | - | - |

* Only recognised in Australia



Off-Shore Helicopter platform, ice prevention systems





Heating Loads - Pipelines

Heat Trace's Evolution design software is able to automatically calculate the appropriate heating load in order to compensate for heat losses from a pipe, vessel and line equipment, or to heat raise the temperature of the equipment and its contents.

It should be stressed that the heat losses from pipeline fittings, such as valves, flanges, strainers, filters, pumps, are often significant, accounting for typically an additional 25% of the pipe work heating load requirements. Also, pipe supports, which are rarely detailed on drawings, can also account for significant heat losses unless the supports are thermally insulated.

Heat loss compensation for pipelines

As its name implies, this form of heating is used to balance or compensate for heat losses from a pipeline to the surrounding atmosphere. The following method may be used to calculate the amount of heat required:

- 1 Table 1a - select loss factor for pipe size and insulation thickness.
- 2 Table 1b - multiply the selected loss factor by the 'K' value of insulation used.
- 3 Multiply the resultant from Tables 1a and 1b by the temperature difference between lowest ambient and required temp ($\Delta t^{\circ}\text{C}$).
- 4 Multiply - by an appropriate safety factor - typically 1.2
- 5 **The resultant number x is the heating load in watts/ metre of pipe**

It should be noted that this heating load is only needed when the ambient temperature is at its minimum design level. At all other times the heating load will be greater than necessary. The excess heating load is normally accommodated by the temperature control system.



Raising temperature of pipelines

In many cases, it is more economic to maintain the heating over short shutdown periods, eg. weekends, than to make provision for heating up from cold. Where it is essential to provide sufficient heat for warming up in addition to heat loss compensation, the time allowed for warming up should be at least 12-24 hours, as shorter periods normally involve inconveniently high loadings.

Heat required for warming up can be calculated as follows:

Formula 1

$$W = \frac{(P \times S) + (C \times Q) \times \Delta T}{E \times H \times 3600} \quad \text{W/m}$$

where

- W = heating required in watts/metre
- P = weight of pipe work in kg/m
- S = specific heat of pipe work in J/kg $^{\circ}\text{C}$
- C = weight of contents in kg/m
- Q = specific heat of contents in J/kg $^{\circ}\text{C}$
- ΔT = temperature rise $^{\circ}\text{C}$
- H = time allowed in hours
- E = efficiency factor, use 0.73 but may vary

This figure must be added to the heat loss compensation calculated previously. It is not necessary to work on the full temperature because, during the heating-up period, the pipe temperature will be below the final temperature, therefore the following equation should be applied:

Total Load = heating up load + 2/3 steady loss at final temperature

Table 1a

| Pipe nominal bore | Pipe O.D | Insulation thickness | | | | | | | |
|-------------------|----------|------------------------|-------|----------|-------|-------|-------|-------|------------|
| | | 12 1/2 | 25 1 | 37 1 1/2 | 50 2 | 75 3 | 100 4 | 125 5 | 150mm 6 in |
| in | mm | Normalised loss factor | | | | | | | |
| 1/2 | 21.35 | 8.01 | 5.16 | 4.13 | 3.58 | | | | |
| 3/4 | 26.7 | 9.39 | 5.89 | 4.65 | 4.00 | 3.30 | | | |
| 1 | 33.4 | 11.34 | 6.91 | 5.36 | 4.56 | 3.71 | | | |
| 1 1/2 | 48.3 | 14.86 | 8.74 | 6.63 | 5.54 | 4.41 | | | |
| 2 | 60.3 | 17.88 | 10.28 | 7.69 | 6.36 | 4.98 | 4.26 | | |
| 2 1/2 | 73.05 | 21.05 | 11.89 | 8.79 | 7.21 | 5.57 | 4.72 | | |
| 3 | 88.9 | 25.00 | 13.90 | 10.15 | 8.24 | 6.29 | 5.28 | | |
| 4 | 114.3 | | 17.08 | 12.30 | 9.88 | 7.42 | 6.15 | | |
| 6 | 169.3 | | 23.82 | 16.82 | 13.30 | 9.74 | 7.93 | 6.83 | |
| 8 | 219.1 | | 30.13 | 21.04 | 16.50 | 11.89 | 9.57 | 8.16 | 7.20 |
| 10 | 273 | | 36.82 | 25.53 | 19.86 | 14.17 | 11.29 | 9.55 | 8.38 |
| 12 | 324 | | 43.12 | 29.73 | 23.03 | 16.29 | 12.90 | 10.85 | 9.47 |
| 14 | 355 | | 47.05 | 32.36 | 25.00 | 17.60 | 13.90 | 11.66 | 10.15 |
| 16 | 406 | | 53.35 | 36.56 | 28.16 | 19.73 | 15.50 | 12.90 | 11.20 |
| 18 | 457 | | 59.64 | 40.76 | 31.31 | 21.84 | 17.08 | 14.22 | 12.30 |
| 20 | 508 | | 65.92 | 44.96 | 34.46 | 23.95 | 18.67 | 15.49 | 13.37 |
| 24 | 609 | | 78.50 | 53.35 | 40.76 | 28.16 | 21.84 | 18.04 | 15.50 |
| 30 | 762 | | 97.36 | 65.92 | 50.20 | 34.60 | 26.58 | 21.84 | 18.60 |



Heating Loads - Tanks & Vessels

Table 1b

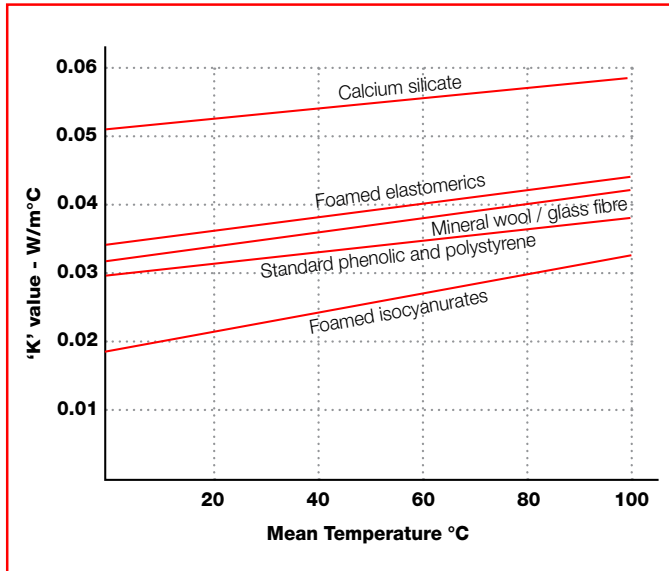

Heat loss compensation for tanks, vessels & hoppers

Similarly the design criteria for calculating heat loss compensating and/or raising and maintaining temperature associated with tanks, vessels, or hoppers are as follows:

Formula 2a (for flat surfaces)

$$\text{Loading required} = \frac{A \times K \times (T_1 - T_2)}{E \times t} \text{ watts}$$

2b (for cylindrical surfaces)

$$\text{Loading required} = \frac{2.72 \times K \times L \times (T_1 - T_2)}{E \times \log_{10}(D/d)} \text{ watts}$$

where

- A = total surface area of tank, vessel, etc. to be heated in square metres (m²)
- K = thermal conductivity of the insulation in W/m°C
- T₁ = temperature to be maintained °C
- T₂ = min. ambient temperature °C
- t = thermal insulation thickness in mm
- L = length of surface
- D = diameter across insulation
- d = outside diameter of pipe
- E = efficiency factor, use 0.73 but may vary

Raising temperature of tanks, vessels and hoppers

Formula 3

Kilowatt loading required =

$$\frac{\text{mass(kg)} \times \text{sp heat (J/kg°C)} \times \text{temp rise °C}}{E(0.73) \times 1000 \times \text{hours} \times 3600} \text{ kW}$$

As for pipe work, it is necessary to consider both the vessel and its contents. Therefore apply the above formula to both vessel and contents and add the respective loads together to arrive at the total kilowatt loading.

After raising the tank and contents to the required level, it will be necessary to allow for heat losses as in FORMULAE 2a or 2b.

Therefore the total heat required = Amount of heat to raise temperature of contents + ²/₃ of amount of heat to maintain temperature.

Types of thermal insulation used for pipelines and vessels together with thermal conductivity, i.e. 'K' factor, are shown in Table 1b.





Temperature Control

Temperature control may be provided to a system in order to:-

- Ensure temperature safety or
- Provide process temperature accuracy

Ensuring temperature safety

As previously stated, it is recommended that the provision of temperature controls to ensure that limiting temperatures are not exceeded should only be considered when the use of inherently temperature-safe heaters or a stabilised design is not possible.

Where this form of temperature safety cannot be avoided, it is necessary that:-

- In safe areas, a controller provided for process control may also act as an over temperature controller
- In Zone 2 areas, two controllers, a process temperature plus an over-temperature are required, and
- In Zone 1 areas, two controllers, a process temperature plus an over-temperature are required, where the over-temperature device is a manually re-settable lock-out type; unless a monitored alarm is provided.

It is important that the sensor of the over-temperature controller is fitted to the pipe or work piece to limit the pipe to a temperature level at which the heater will not exceed the maximum limiting temperature.

Warning:

It is legal to fit the sensor of the over-temperature controller to the surface of the heater itself. However, this is a practice that Heat Trace Ltd. does not recommend because:-

- It will rarely be known to be sensing the hottest point of the heater (which is likely to be where the heater is out of contact with the equipment) and
- When the sensor is removed, for example during maintenance work, it cannot be guaranteed to be returned to the hottest part of the heater

THE PRACTICE OF FITTING A TEMPERATURE SENSOR TO THE HEATER TO ENSURE TEMPERATURE SAFETY IS DANGEROUS!



Temperature Controller

Process temperature accuracy

The IEC electric heat tracing standards define 3 levels of process temperature accuracy

Type I

A Type I process is one in which the temperature should be maintained **above a minimum point**. No temperature control or simple ambient sensing control may be acceptable. Large blocks of power may be controlled by means of a single device.

Type II

A Type II process is one in which the temperature should be maintained **within a moderate band**.

Type III

A Type III process is one in which the temperature should be controlled **within a narrow band**. Type III systems require strict adherence to flow patterns if surface sensing controls are utilised.





Circuit Monitoring

Circuit Monitoring

If failure of a heater can result in a safety or process problem, then the heat tracing system may be considered to be critical to the total process. The temperature control and circuit monitoring requirements of an application are defined by the IEC Electric Heat Tracing standards according to the temperature control types as previously described, together with the circuit monitoring criticality as described in the table below.

| Is heat tracing a critical component of the process? | Desired accuracy of process temperature control | | |
|--|---|---|--|
| | Maintain above a minimum point Type I | Maintain within a moderate band Type II | Maintain within a narrow band Type III |
| Yes = Critical (C) | C – I | C – II | C – III |
| No = Non-critical (NC) | NC – I | NC – II | NC – III |



Temperature Controller with Monitoring

Process types

When heat tracing is critical to the process, circuit monitoring for correct operation is recommended. Malfunction alarms, and back-up (redundant) heat tracers may also be considered. Spare or back-up controllers can be specified to be automatically activated in the event of a fault being indicated by the monitoring / alarm system. This is sometimes known as "redundancy". Back-up heat tracers will maintain availability and may allow maintenance or repairs to be performed without a process shutdown.

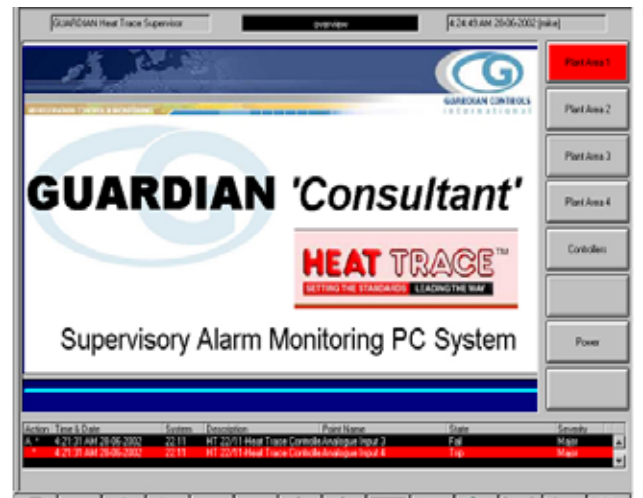



Heating Cables - Generic types

There are four generic types of heat tracer

- Parallel Self-Regulating
- Parallel Constant Power
- Series Resistance
- Skin-Trace

Parallel Self-Regulating

Self-Regulating (or self-limiting) tracers are most popular, as they can conveniently be cut-to-length and are often inherently temperature-safe, due to the positive temperature coefficient heating matrix. Thus temperature control is not usually needed to provide temperature safety.

Until recently, their availability for only low or moderate temperatures limited their use. Now though, Heat Trace Ltd. have pioneered new 3rd generation semi-conductive tracers able to withstand up to 300°C energised or power off, meaning only Heat Trace's Self-Regulating tracers can fulfil 90% of all applications within industrial heat tracing - but currently only from Heat Trace.

Ever since the introduction of self-regulating tracers, the high currents on start up from cold have created a problem requiring the need for larger than necessary feed cables and switchgear. Additionally, safety was compromised, as circuit protection had to be sized in excess of operating currents. Now however, Heat Trace has made significant reductions in start currents, thereby improving safety, and reducing distribution costs.

A patented **SoftStart** device is currently under development having NTC (negative temperature coefficient) characteristics negates the PTC (positive temperature coefficient) of the heating matrix. Start currents are reduced by about 50% (see Figure below). This is further aided by a patented processing method known as Directional Conductivity. Here the conductive particles within the heating matrix are dispersed and distributed in such a way as to control the direction of current flow.

Single phase Self-Regulating tracers are typically limited in circuit length to 100 or 200 metres, and so are used mainly for in-plant applications. However Heat-Trace can now provide the world's first 3 phase self-regulating tracer capable of circuit lengths upto 600m.

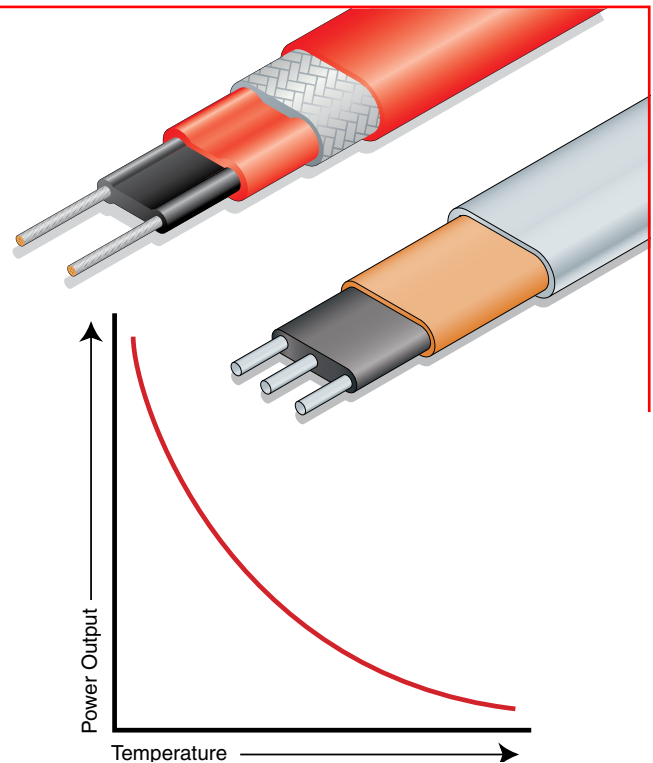

Heat Trace's range of self regulating heat tracers

Heat Trace Limited is able to produce self-regulating tracers within the following range:

- 12 - 1000 Volts
- Up to 300°C withstand temperature
- Up to 150 W/m

Datasheets for some of the standard Heat Trace range are provided, pages 30 - 35 inclusive

Temperature ranges:

Low

- FSR 85°C On or Off - up to 40W/m
- FSE 100°C On or Off - up to 60W/m

High

- FS+ 225°C On or Off - up to 60W/m
- FSS 225°C On or Off - up to 75W/m
- FSU 250°C On or Off - up to 100W/m
- FSU+ 275°C On or Off - up to 125W/m
- AFS 300°C On or Off - up to 150W/m



Heating Cables - Generic types

Parallel Constant Power

Parallel Constant Power (zonal) tracers can be conveniently cut-to-length, but are less popular than Self-Regulating heaters, because they often require thermostatic control to ensure temperature safety, (although sometimes a calculated temperature-safe stabilised design is possible).

Until recently, all constant power tracers were polymeric, and so were limited in temperature capability. However, Heat Trace has patented a parallel resistance, convenient cut-to-length metal sheathed, mineral insulated (MI) heater having a withstand temperature of 500 deg. C. This type **AHT** product caters for most applications that the new high temperature Self-Regulating heaters are unable to handle. Thus cut-to-length parallel tracers are now available for virtually all heat tracing applications.

This is particularly beneficial in the case of instrument lines, the lengths of which are usually unknown at the design stage of a project, and which are site run according to convenience.

Parallel Constant Power tracers are typically limited in circuit length to 100 or 200 metres, and so are used mainly for in-plant applications

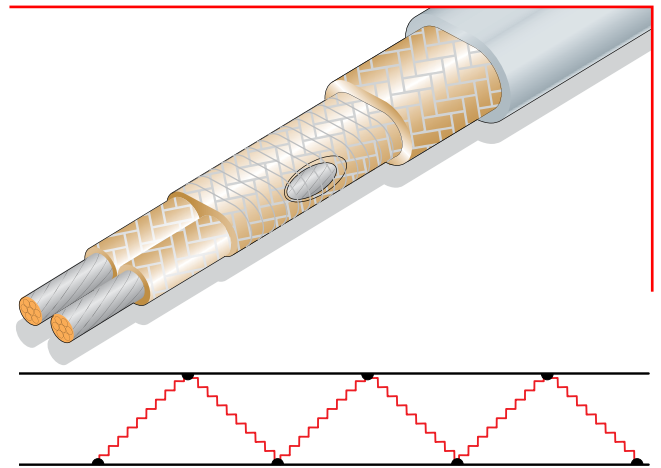

Parallel heating zones

Heat Trace's range of Parallel Constant Power heat tracers

Heat Trace Limited is able to produce tracers within the following limitations

Up to 500°C withstand temperature
Up to 200 W/m

Datasheets of some of the standard Heat Trace range are provided, pages 36 - 39 inclusive

Temperature ranges:

Medium

MTF 200°C On or Off - up to 50W/m
EMTF 200°C On or Off - up to 50W/m

High

PHT 275°C On or 285°C Off - up to 70W/m
AHT 500°C On or Off - up to 150W/m)





Heating Cables - Generic types

Series Resistance Tracers

Series Resistance Tracers have to be individually designed into particular length/load configurations and so are not so versatile as parallel types.

However, an advantage is that very long circuit lengths are possible – typically 3 phase ‘Longline’ tracers require electric supply points only at multi-kilometre intervals. So the major outlet for series heaters is long pipelines.

Traditionally, metal sheathed, mineral insulated (MI) series cables were used when process temperatures exceeded the capability of the more convenient polymeric parallel tracers. However, the introduction of Heat Trace’s cut-to-length parallel type AHT MI tracer virtually eliminates the need for series MI tracers which require skill to terminate and are costly.

Series Resistance Tracers often require temperature controls to ensure temperature safety.

Heat Trace’s range of series ‘Longline’ heat tracers

Heat Trace Limited is able to produce tracers within the following limitations

- Up to 6.6kV Volts 3 phase
- Up to 300°C withstand temperature
- Up to 200 W/m of pipe

Datasheets of some of the standard Heat Trace range are provided, pages 40 - 43 inclusive

Temperature ranges

| Low | Medium | High |
|------|--------|--------|
| HTP3 | HTS3F | HT/A3F |
| HTP1 | HTS1F | HT/A1F |

Longline series resistance tracers are for the heating of very long pipelines, a very competitive option to Skin Trace.

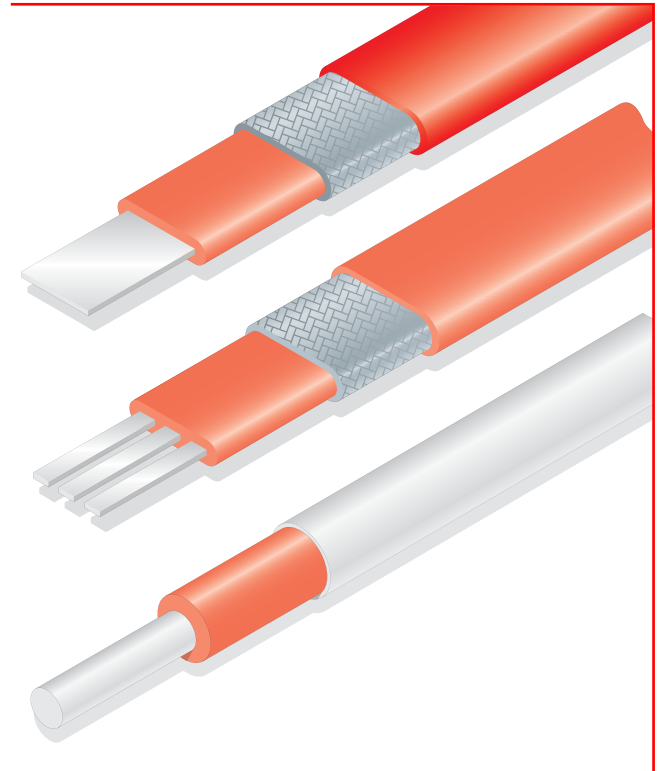

Heating Circuit Configuration

A 3 phase circuit configuration comprises either 1 x three foil Longline heater or 3 x single foil Longline heaters.





Heating Cables - Generic types

Skin-Trace

Skin-Trace is induction-resistive heat tracing based on skin and proximity effects of an AC current within a ferromagnetic tube.

The heating element comprises a carbon steel tube into which is inserted an insulated non-magnetic conductor. The conductor and the steel tube are connected together at one end. At the other end an AC voltage is applied between the conductor and the tube. The relationship of conductor/tube sizes and voltage determines the output power developed.

The skin effect of the magnetic tube results in the current being concentrated towards the tube's inner surface, the potential to the outside being zero.

Skin-Trace's advantage is that long circuit lengths are possible – typically a pipeline of up to 20km may be heated from a single electric supply point. So Skin-Trace is most appropriate for the heating of cross-country pipelines.

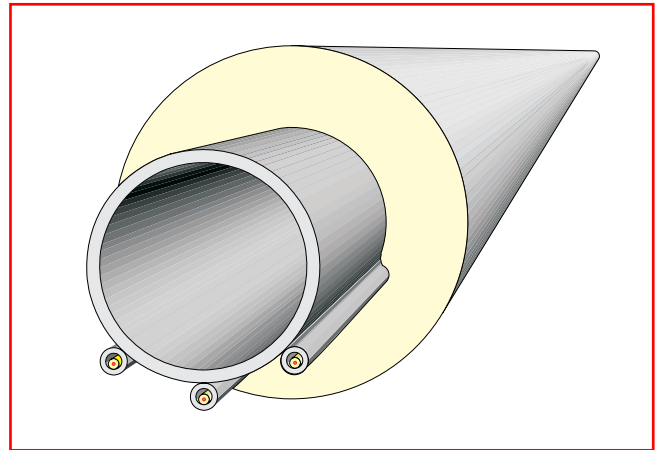

Depending on the heating power required and the pipeline length, SKIN-TRACE may consist of either one, two, or three, heater tubes (see image above).

OPERATING TEMPERATURE -40°C to +200°C

POWER SUPPLY up to 3kV AC 50 or 60 Hz

POWER OUTPUT

Rated power output of one heating element

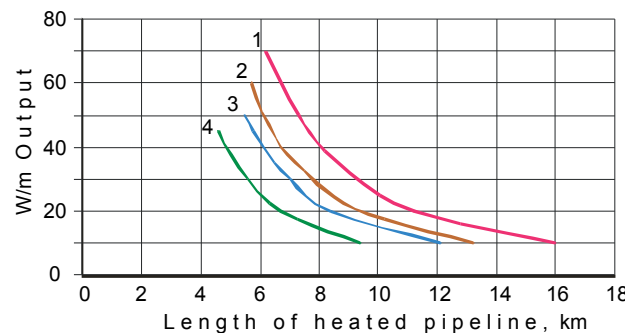

Rated Power output of one heater tube, W/m

Heater Tube Dimension

- 1 ————— 40mm
- 2 ————— 25mm
- 3 ————— 19mm
- 4 ————— 10mm

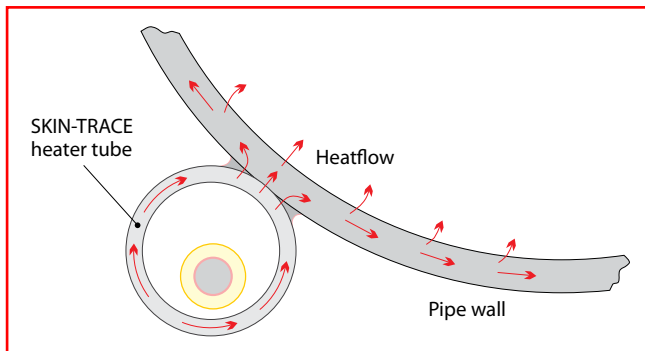

- Typically up to 20 km lines heated from one supply point
- Robust and reliable system with outputs up to 120W/m
- Suitable for up to 200°C operating temperature
- Suitable for use in hazardous areas





Heating Cables – Selection Guide

● In-plant areas

Heat tracers for in-plant areas are usually selected according to the maximum temperature to which the tracer will be subjected, and the power output required from the tracer.

The following table shows the relationship between temperature withstand and power output for various self-regulating, constant power, and series MI tracers. It may be seen that self-regulating tracers, which can be conveniently cut-to-length and which are usually temperature-safe, are available for exposure temperatures up to 300°C.

AHT constant power tracers can cater for higher exposure temperatures up to 500°C and high power outputs up to 150W/m.

Only exceptionally is it necessary to employ series MI cables, which must be specifically designed for a particular length and output.

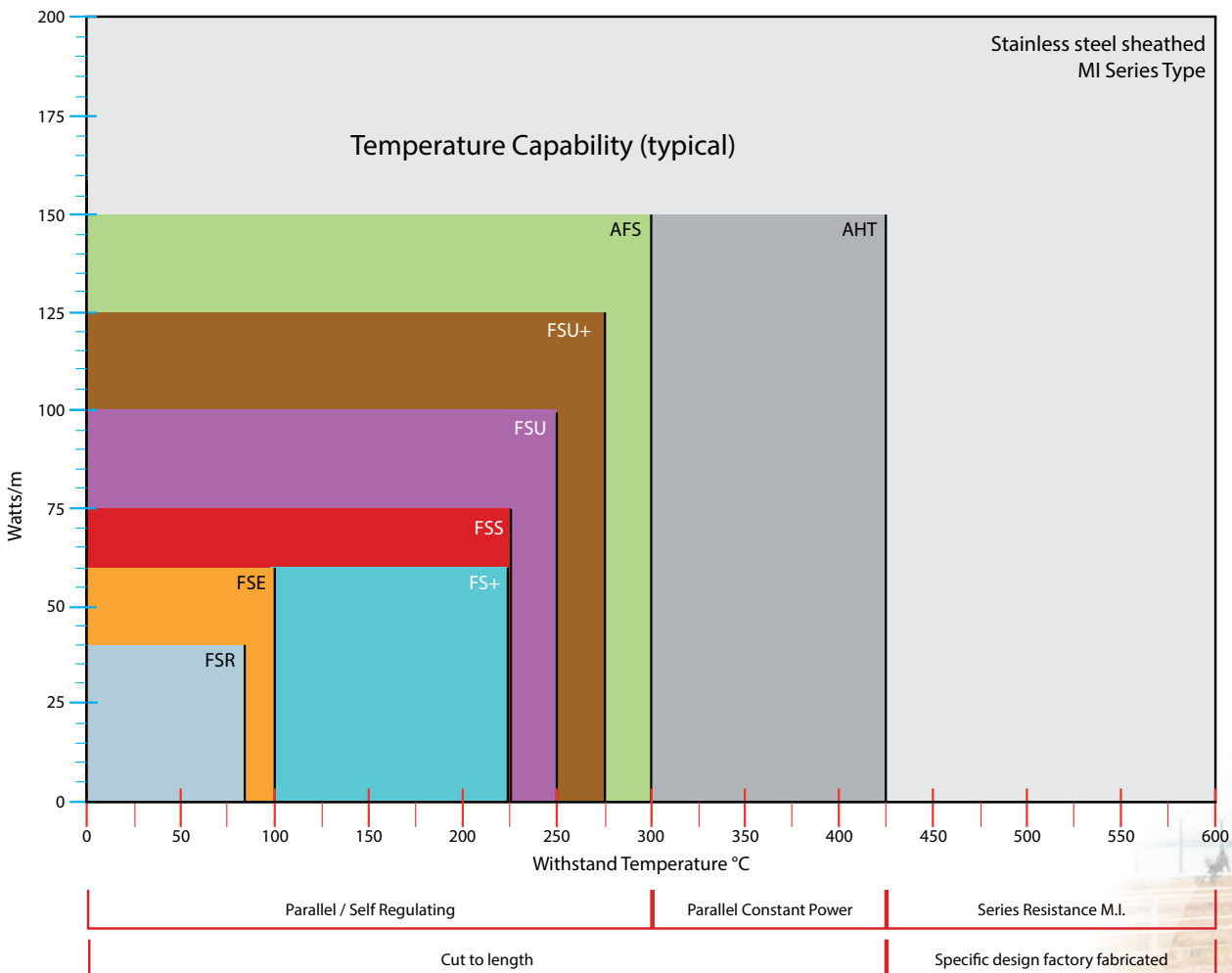



Heating Cables – Selection Guide

● Transfer and long pipe runs

Until recently, parallel resistance heaters – self-regulating or constant power – were limited by volt drop to around 150 metres circuit length.

Now, Heat Trace's patented 3 phase self-regulating tracer, particularly when connected to an elevated voltage e.g. 600 volts, is capable of circuit lengths of up to 700 metres. Consequently, inherently temperature-safe heating systems are now available for applications previously not possible.

Beyond 700 metres, it is necessary to select series resistance 3 phase Longline heating cables, which have the capability to extend to, for example, 5km.

For very long pipe runs, e.g. >10km from a single electrical supply point, there was, until recently, no alternative to the Skin-Trace, skin-effect heating system. However, Heat Trace's new continuous metal extrusion facility has enabled Longline systems to heat up to 50km of pipe from a single electrical feed point.

The advantages of the Longline system over Skin-Trace are:-

- Lower capital cost
- Cheaper/ simpler installation
- Lower operating costs (Skin-Trace power factor is 0.85 against the unity factor of Longline)



Circuit Length (typical) - Metres

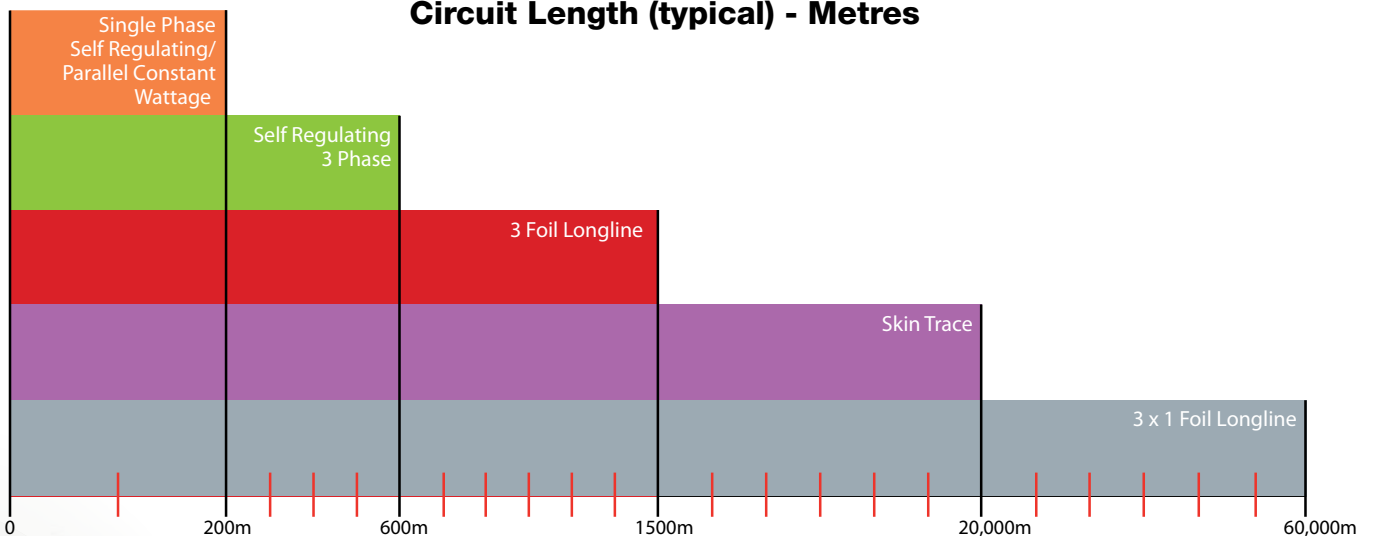



Typical Long Pipeline Applications

Heater selection is usually governed by the pipe length. Some interesting selections and applications are:-

'Downhole' oilwells

In these, oil exits the reservoir into the production tube at high temperature, cooling as it rises to the surface. To prevent the oil temperature falling below its pour point where waxing can occur on the walls of the production tube, the upper sections of the tube may be heated.

In 'Downhole' applications of heated depths to 700 metres, the benefits of inherently temperature-safe self-regulating heaters are preferred. The principle of self-regulating is attractive, because progressively more heat is produced as the oil rises towards the surface, cools, and the temperature falls. In the past this has not been feasible, but Heat Trace have developed the world's first self-regulating 3 phase heater, a patented product based on it's unique phase-balanced load design.

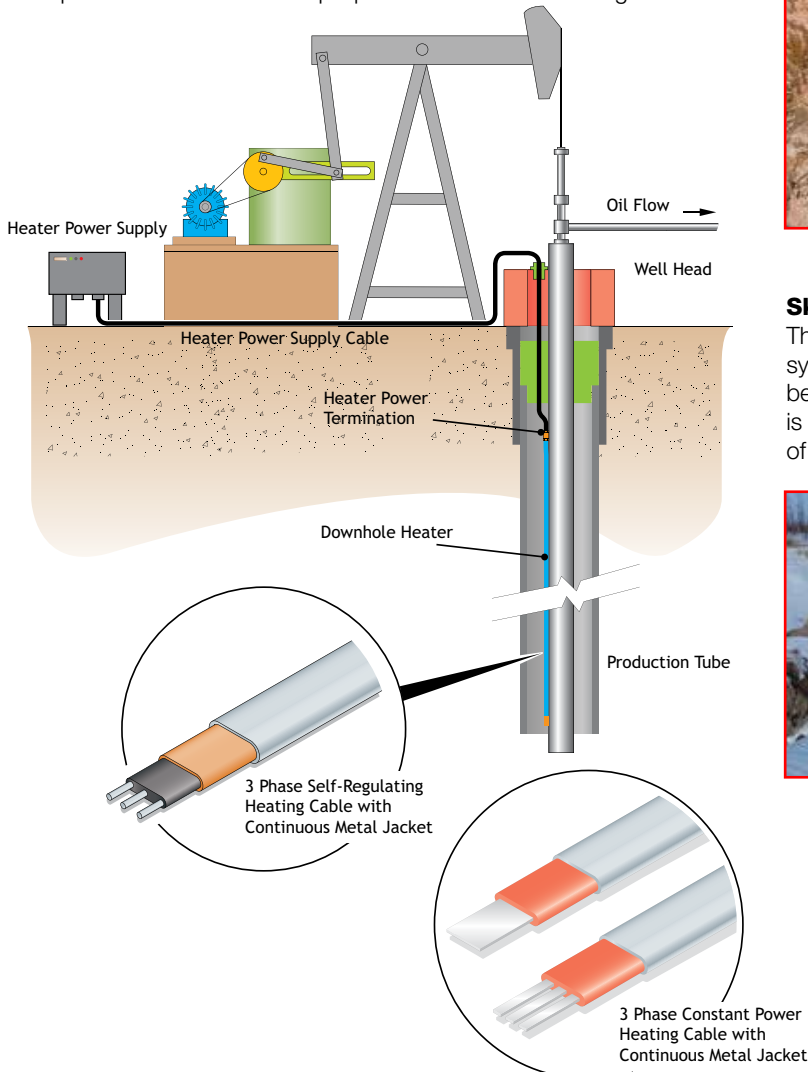

In another well, requiring heating down to 2km, a unique Heat Trace Longline product can be provided with heating conductors whose power output varies from point to point along the pipe route within a single heating cable. Heat Trace's conductor extrusion facility is able to vary it's cross-section, and hence the power output, at will in a continuous extruded length.

Long Pre-insulated Pipelines

The picture below shows a typical long pipeline application where a pre-insulated pipeline is fitted with an HTS3F-CS LONGLINE series resistance heating cable. The pre-insulated pipe is constructed with a metal "raceway" during construction. The heating cable is pulled through the raceway on site as the pre-fabricated pipe lengths are joined together at site, prior to being buried. The pipeline was carrying crude oil from the on-land oil well to a central gathering station.



Buried, Pre-insulated Pipe with Longline HTS3F

Skin Effect Heat Tracing

The picture below shows a completed skin effect tracing system prior to being buried. Skin effect tracing systems may be employed for very long cross-country pipelines. Skin trace is an inductive heating system and may be used for pipelines of up to 30km circuit lengths from a single power supply.



Completed Skin Trace system prior to burying



Off-shore Applications

Off-shore Applications

As one of the world's leading suppliers of electric heat tracing products, Heat Trace Limited (HTL) can provide a wide range of heaters and ancillary products that are particularly suited to offshore applications.

In the harsh off-shore environment, safety and reliability are high priorities and HTL is able to supply high quality products and services to meet the demands of the industry. Heaters for subsea pipelines and risers, topside pipeline heating for both freeze protection and temperature maintenance, helicopter platform snow and ice prevention systems, under-floor heating for accommodation - these are just some of the application solutions available from Heat Trace Limited.



Completed electrically heat-traced pipe-in-pipe being reeled onto the pipelay vessel.

In-shore Applications

Subsea pipelines for in-shore applications are also used extensively around the world. A typical application might be a fuel tanker off-loading facility for an on-shore plant or power station. These systems are generally run from the on-shore plant storage tank, across the shore line and out to a PLEM located on the seabed and attached to a CALM buoy. The subsea section of the pipe can vary, usually between 1 - 3km from the shore, depending on the depth of water. The pipelines for these applications generally use pre-insulated pipe sections fitted with raceways for the heating cables. These sections are joined together on-shore and the completed pipeline floated/towed into position prior to sinking to the seabed. Alternatively, the pipe sections can be assembled and laid from a barge. Due to the shallow water, these pipelines are usually laid in a trench, or protected in some way, such as a "rock dump".

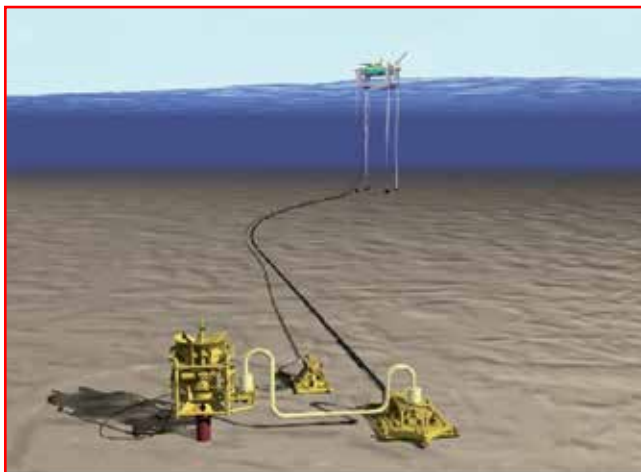

Typical subsea tie back from well head to production platform

Subsea Pipeline Heating

Heat Trace's 'Longline' heating system has recently been installed on the world's first reelable heat traced, subsea pipe-in-pipe for a 6.5km gas condensate pipeline, using 75km of heating conductors produced by our new continuous metal extrusion facility. The 2kV system is capable of maintaining the required pipeline temperatures from a single electrical supply point in a 3 phase balanced load configuration by a single heating cable. Temperature control and system monitoring is achieved through the use of fibre optic cables installed with the heaters on the inner production flowline. At the time of writing, several other larger subsea installations, for pipelines up to 50km in length, are in the process of being designed. Heat Trace's heat tracing system for pipe-in-pipe systems are suitable for relatively shallow water applications of around 80-100m depth or for deep sea applications down to 2500 - 3000 metres.



Helicopter platform, ice prevention systems

FOR FURTHER INFORMATION ON LONG PIPELINE HEATING SYSTEMS PLEASE VISIT OUR WEBSITE AND READ OUR BLOG FROM NOVEMBER 2022 ABOUT "ELECTRIC HEAT TRACING OF LONG PIPELINES" www.heat-trace.com



Product Data - Parallel Self-Regulating Heaters to 100°C

FREEZSTOP - Low Temperature Range Self-Regulating Heating Cables for exposure temperatures up to 100°C

A versatile range of industrial grade self-regulating heating cables for freeze protection and **low** process temperature maintenance duties. All cables are available with a choice of flexible metallic braid or continuous metallic extruded jacket. Further corrosion resisting overjacket in thermoplastic or fluoropolymer is optional. Approved for use in both safe and hazardous areas. Available for voltages 100 – 120VAC and 208 – 277VAC.

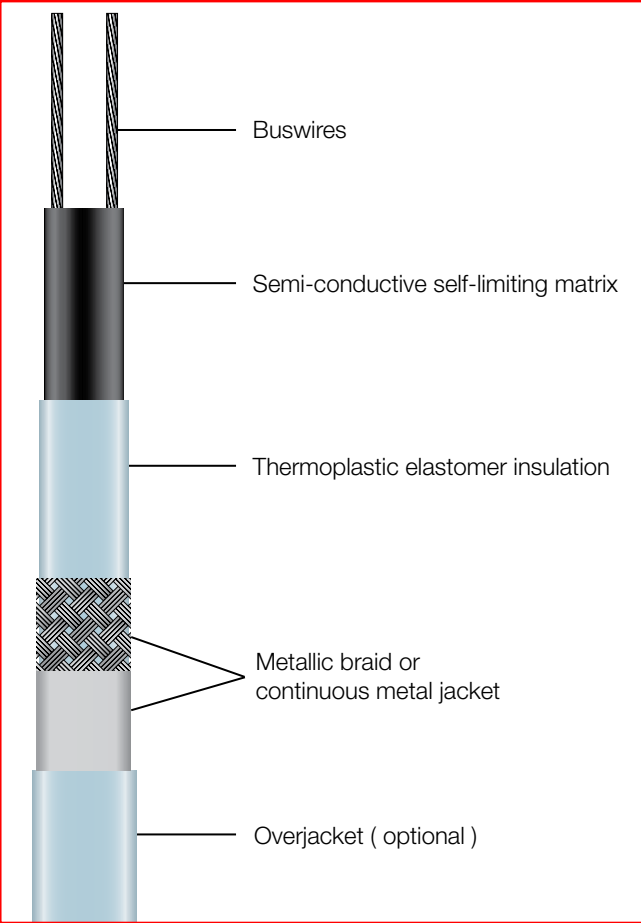

FREEZSTOP MICRO

FSM withstand temperatures - 65°C energised / 85°C un-energised.

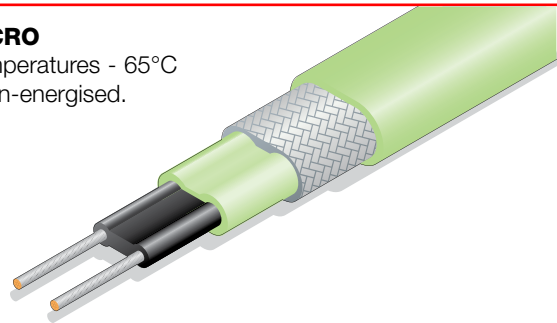

FREEZSTOP REGULAR

FSR withstand temperatures - 85°C energised / 85°C un-energised.

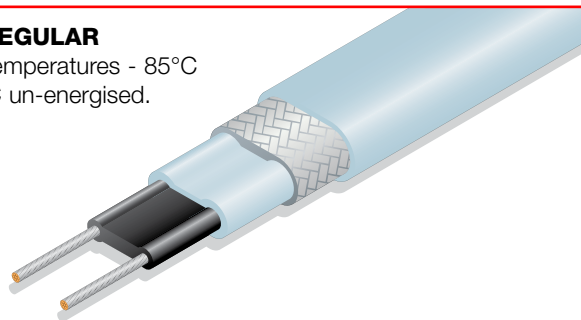

FREEZSTOP EXTRA

FSE withstand temperatures - 100°C energised / 100°C un-energised.

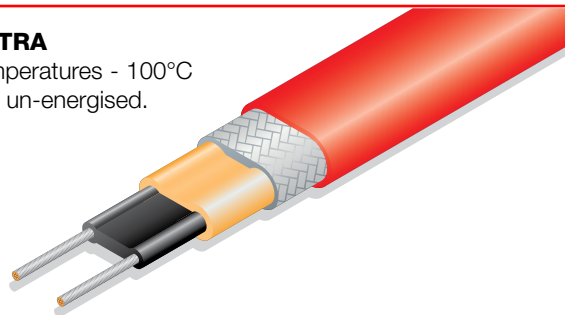

Low Temperature

- Use Type C or D motor rated circuit breakers
- Maximum circuit lengths are based on a start up temperature of 10°C
- If circuits are started up when heaters are below 10°C, circuit breakers may trip. If this happens, re-energise the circuits until the heaters warm up, and circuit breakers remain switched on
- For maximum circuit lengths for start up temperatures below 10°C, please consult Heat Trace Limited
- **THERMAL RATINGS**
Nominal power output at 115V or 230V when installed on insulated metal pipes.





Product Data - Parallel Self-regulating Heaters to 100 °C

MICRO - FSM Specification Data

MAXIMUM LENGTH (m) vs. CIRCUIT BREAKER SIZE

| Cat Ref | 115V | | 230V | |
|--------------|------|-----|------|-----|
| | 6A | 16A | 6A | 16A |
| 11FSM | 38 | 64 | 76 | 128 |
| 17FSM | 27 | 51 | 54 | 102 |

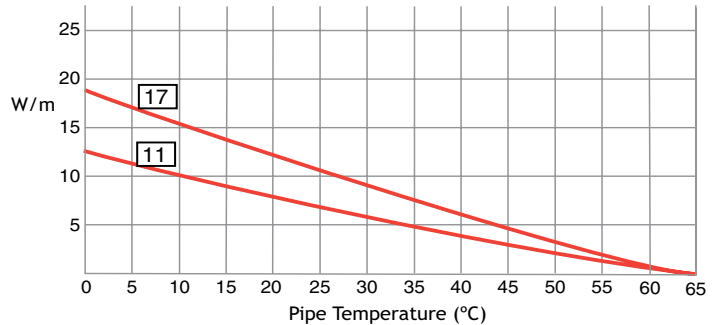

REGULAR - FSR Specification Data

MAXIMUM LENGTH (m) vs. CIRCUIT BREAKER SIZE

| Cat Ref | 115V | | | 230V | | |
|--------------|------|-----|-----|------|-----|-----|
| | 16A | 20A | 32A | 16A | 20A | 32A |
| 10FSR | 99 | 99 | 99 | 198 | 198 | 198 |
| 17FSR | 74 | 76 | 76 | 148 | 152 | 152 |
| 25FSR | 59 | 62 | 62 | 118 | 124 | 124 |
| 31FSR | 46 | 56 | 56 | 92 | 112 | 112 |
| 40FSR | 37 | 46 | 49 | 74 | 92 | 98 |

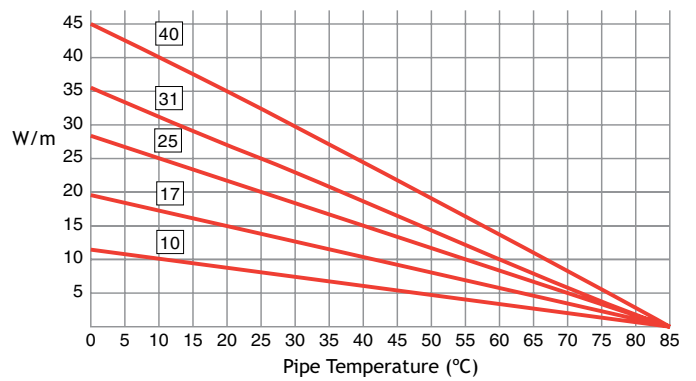

Extra - FSE Specification Data

MAXIMUM LENGTH (m) vs. CIRCUIT BREAKER SIZE

| Cat Ref | 115V | | | 230V | | |
|---------------|------|-----|-----|------|-----|-----|
| | 16A | 20A | 25A | 16A | 20A | 25A |
| 17FSE | 60 | 74 | 74 | 120 | 148 | 148 |
| 31FSE | 41 | 52 | 55 | 82 | 104 | 110 |
| 45FSEw | 31 | 38 | 48 | 62 | 76 | 96 |
| 60FSEw | 26 | 33 | 41 | 52 | 66 | 82 |

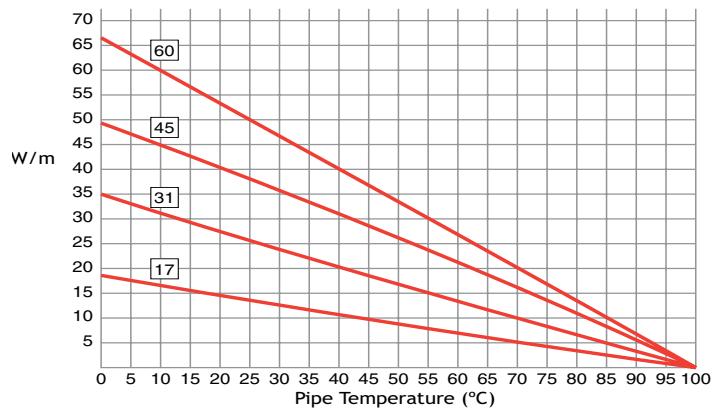

FULL TECHNICAL DATA SHEETS ARE AVAILABLE ON OUR WEBSITE FOR ALL PRODUCTS
www.heat-trace.com

Low Temperature



Product Data - Parallel Self-Regulating Heaters to 250°C

FAILSAFE - High Temperature Range Self-Regulating Heating Cables for exposure temperatures up to 250°C

A versatile range of industrial grade self-regulating heating cables for freeze protection and **high** process temperature maintenance duties. All cables are available with a choice of flexible metallic braid or continuous metallic extruded jacket. Further corrosion resisting overjacket in silicone rubber or fluoropolymer is optional. Approved for use in both safe and hazardous areas. Available for voltages 100 – 120VAC and 208 – 277VAC.

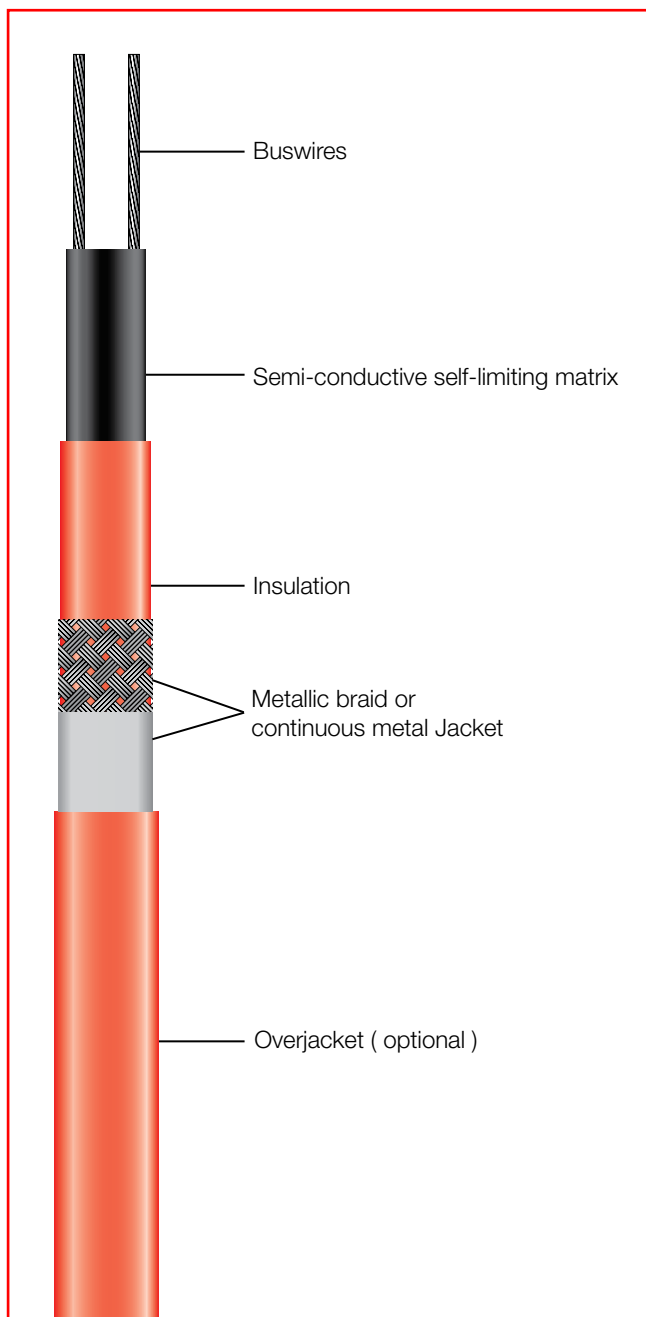

High Temperature

FAILSAFE +

FS+ withstand temperatures - 225°C energised / 225°C un-energised.

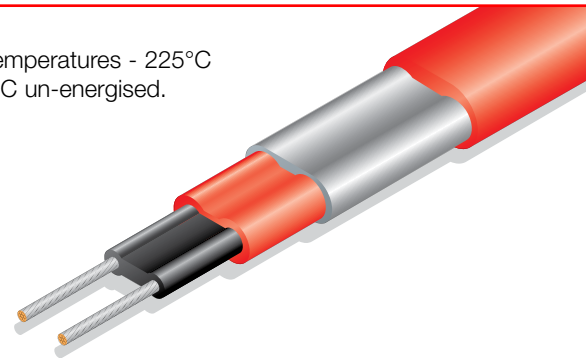

FAILSAFE SUPER

FSS withstand temperatures - 225°C energised / 225°C un-energised.

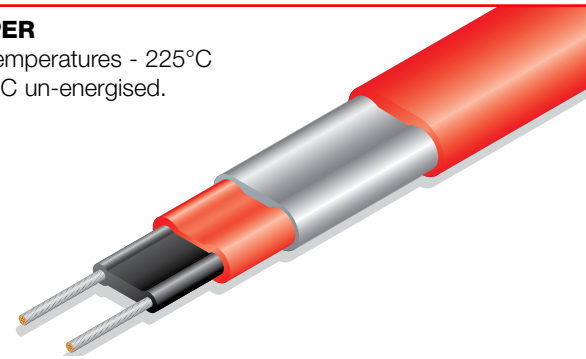

FAILSAFE ULTIMO

FSU withstand temperatures - 250°C energised / 250°C un-energised.

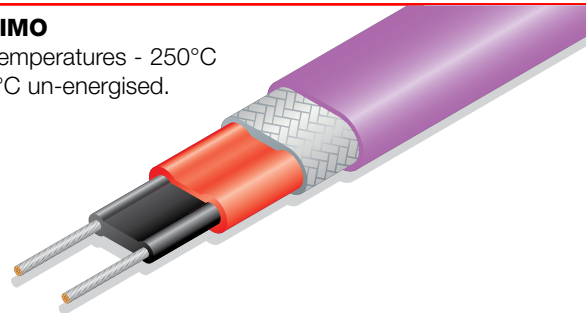

- Use Type C or D motor rated circuit breakers
- Maximum circuit lengths are based on a start up temperature of 10°C
- If circuits are started up when heaters are below 10°C, circuit breakers may trip. If this happens, re-energise the circuits until the heaters warm up, and circuit breakers remain switched on
- For maximum circuit lengths for start up temperatures below 10°C, please consult Heat Trace Limited
- **THERMAL RATINGS**
Nominal power output at 115V or 230V when installed on insulated metal pipes.



Product Data - Parallel Self-regulating Heaters to 250 °C

FAILSAFE + Specification Data

MAXIMUM LENGTH (m) vs. CIRCUIT BREAKER SIZE

| Cat Ref | 115V | | | 230V | | |
|--------------|------|-----|-----|------|-----|-----|
| | 16A | 20A | 32A | 16A | 20A | 32A |
| 15FS+ | 61 | 77 | 77 | 122 | 154 | 154 |
| 30FS+ | 41 | 51 | 54 | 82 | 102 | 108 |
| 45FS+ | 31 | 38 | 44 | 62 | 76 | 88 |
| 60FS+ | 19 | 23 | 38 | 38 | 46 | 76 |

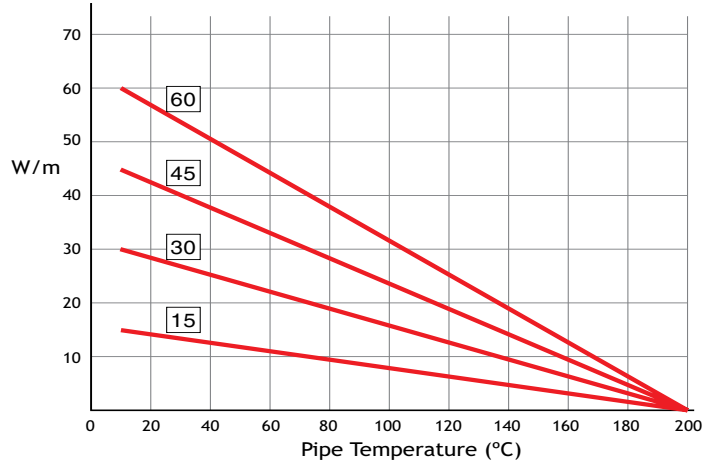

FAILSAFE SUPER Specification Data

MAXIMUM LENGTH (m) vs. CIRCUIT BREAKER SIZE

| Cat Ref | 115V | | | 230V | | |
|--------------|------|-----|-----|------|-----|-----|
| | 16A | 20A | 32A | 16A | 20A | 32A |
| 15FSS | 61 | 77 | 77 | 122 | 154 | 154 |
| 30FSS | 41 | 51 | 54 | 82 | 102 | 108 |
| 45FSS | 31 | 38 | 44 | 62 | 76 | 88 |
| 60FSS | 19 | 23 | 38 | 38 | 46 | 76 |
| 75FSS | 12 | 14 | 23 | 24 | 28 | 46 |

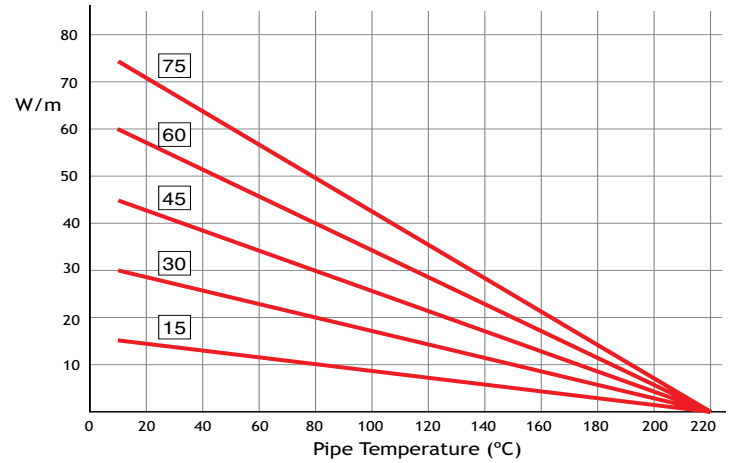

FAILSAFE ULTIMO Specification Data

MAXIMUM LENGTH (m) vs. CIRCUIT BREAKER SIZE

| Cat Ref | 115V | | | 230V | | |
|----------------|------|-----|-----|------|-----|-----|
| | 16A | 20A | 32A | 16A | 20A | 32A |
| 15FSU | 61 | 77 | 77 | 122 | 154 | 154 |
| 30FSU | 41 | 51 | 54 | 82 | 102 | 108 |
| 45FSU | 31 | 38 | 44 | 62 | 76 | 88 |
| 60FSU | 19 | 23 | 38 | 38 | 46 | 76 |
| 75FSU | 12 | 14 | 23 | 24 | 28 | 46 |
| 100FSUw | 11 | 14 | 23 | 22 | 28 | 46 |

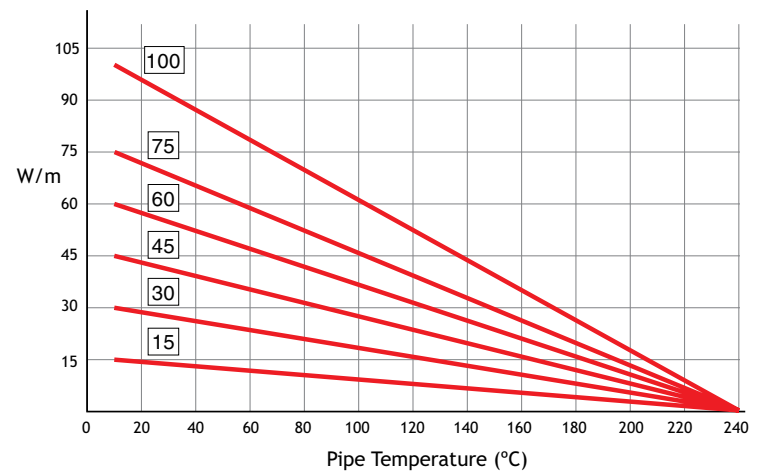

FULL TECHNICAL DATA SHEETS ARE AVAILABLE ON OUR WEBSITE FOR ALL PRODUCTS
www.heat-trace.com

High Temperature



Product Data - Parallel Self-Regulating Heaters to 300°C

FAILSAFE - Ultra High Temperature Range Self-Regulating Heating Cables for exposure temperatures up to 300°C

A versatile range of industrial grade self-regulating heating cables for freeze protection and **ultra high** process temperature maintenance duties.

All cables are available with a continuous extruded patented metal coating for earth protection and mechanical strength and optionally with a fluoropolymer outer jacket. Approved for use in both safe and hazardous areas. Available for voltages from 12 – 1000V (AC or DC).

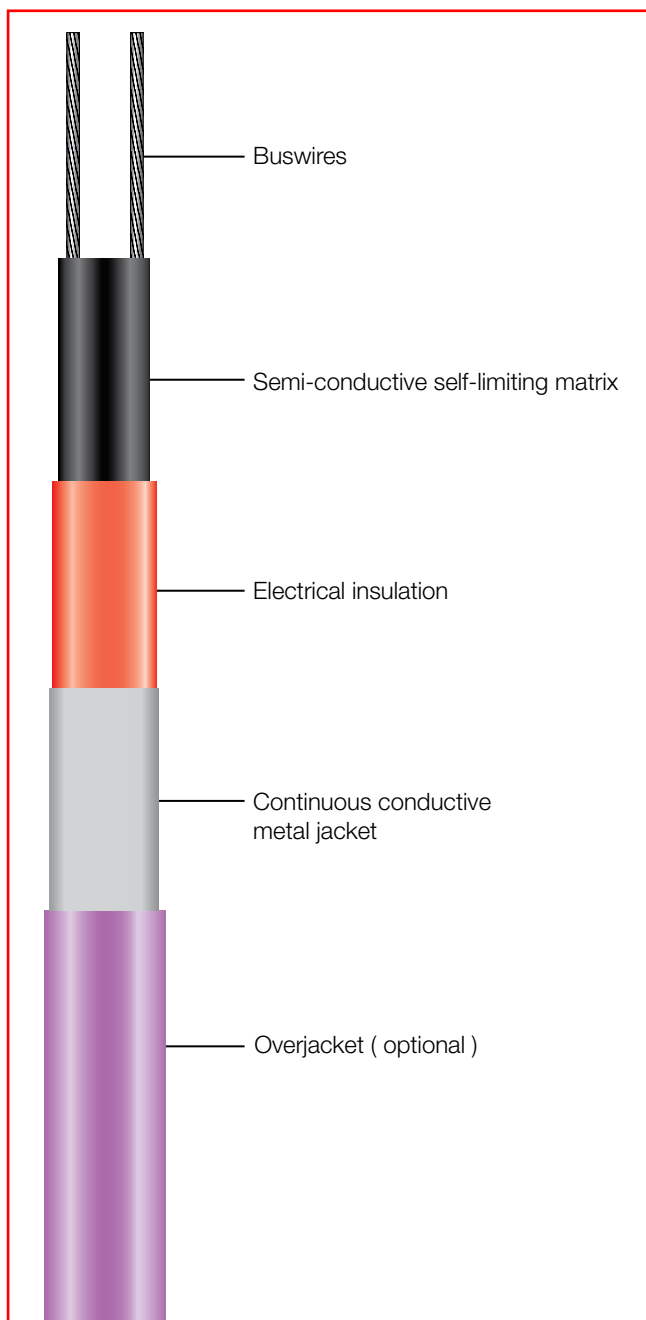

Very High Temperature

FAILSAFE ULTIMO+

FSU+ withstand temperatures - 275°C energised / 275°C un-energised.

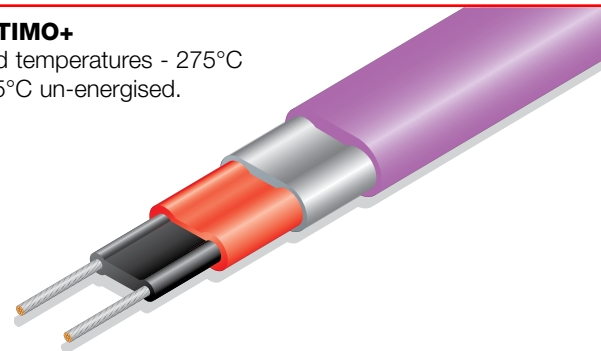

AUTO FAILSAFE

AFS withstand temperatures - 300°C energised / 300°C un-energised. (reduced to 275°C when overjacket is provided).

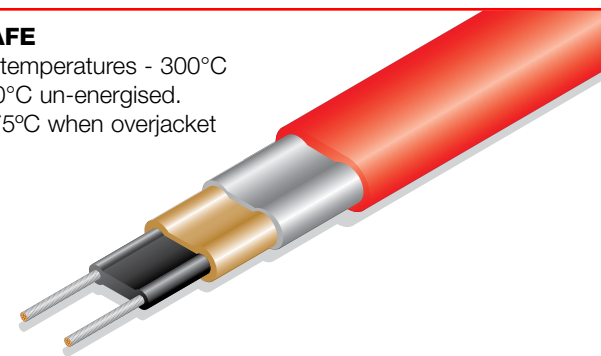

- **Use Type C or D motor rated circuit breakers**
- **Maximum circuit lengths are based on a start up temperature of 10°C**
- **If circuits are started up when heaters are below 10°C, circuit breakers may trip. If this happens, re-energise the circuits until the heaters warm up, and circuit breakers remain switched on**
- **For maximum circuit lengths for start up temperatures below 10°C, please consult Heat Trace Limited**
- **THERMAL RATINGS**
Nominal power output at 115V or 230V when installed on insulated metal pipes.



Product Data - Parallel Self-regulating Heaters to 300 °C

ULTIMO - FSU+ Specification Data MAXIMUM LENGTH (m) vs. CIRCUIT BREAKER SIZE

| Cat Ref | 115V | | 230V | |
|-----------------|------|-----|------|-----|
| | 20A | 32A | 20A | 32A |
| 15FSU+ | 77 | 77 | 154 | 154 |
| 30FSU+ | 51 | 54 | 102 | 108 |
| 45FSU+ | 38 | 44 | 76 | 88 |
| 60FSU+ | 23 | 38 | 46 | 76 |
| 75FSU+ | 14 | 23 | 28 | 46 |
| 100FSU+w | 14 | 23 | 28 | 46 |
| 125FSU+w | 8 | 12 | 16 | 24 |

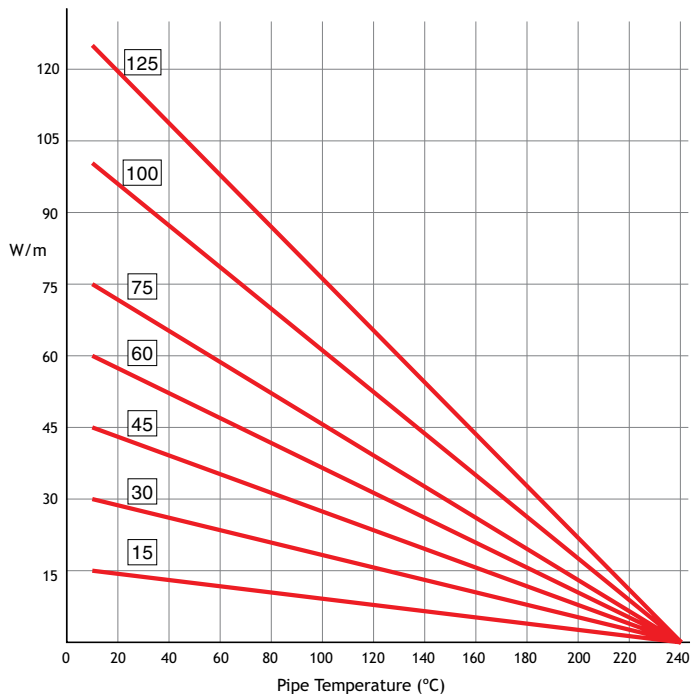

AUTO - AFS Specification Data MAXIMUM LENGTH (m) vs. CIRCUIT BREAKER SIZE

| Cat Ref | 115V | | | 230V | | |
|---------------|------|-----|-----|------|-----|-----|
| | 20A | 32A | 63A | 20A | 32A | 63A |
| 15AFS | 77 | 98 | 98 | 154 | 196 | 196 |
| 30AFS | 46 | 69 | 69 | 92 | 138 | 138 |
| 50AFS | 31 | 49 | 54 | 62 | 98 | 108 |
| 75AFS | 23 | 37 | 44 | 46 | 74 | 88 |
| 100AFS | 14 | 23 | 38 | 28 | 46 | 76 |
| 125AFS | 8 | 14 | 24 | 16 | 24 | 48 |
| 150AFS | 4 | 7 | 14 | 8 | 14 | 28 |

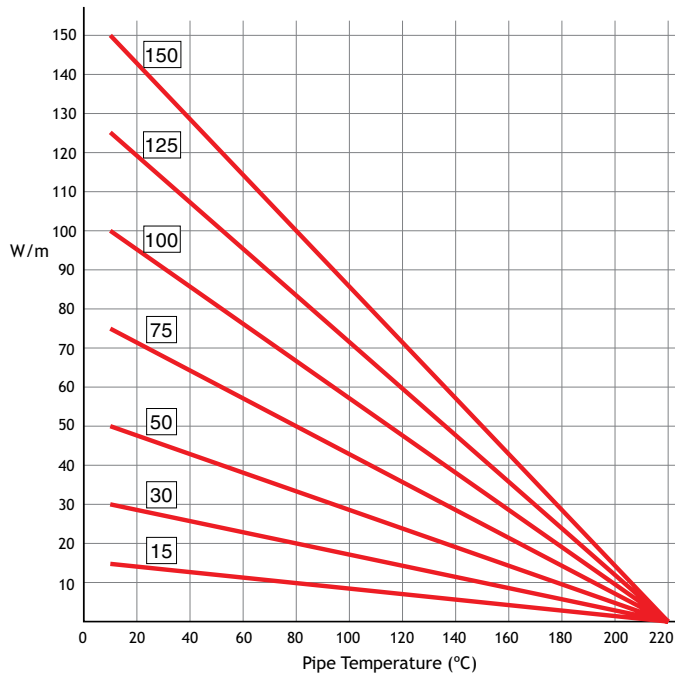

FULL TECHNICAL DATA SHEETS ARE AVAILABLE ON OUR WEBSITE FOR ALL PRODUCTS
www.heat-trace.com

Very High Temperature



Product Data - Parallel Constant Power Heaters to 200°C

MINITRACER - Low to Medium Temperature Range Parallel Constant Power Heating Cables for exposure temperatures up to 200°C

Types MTF and EMTF are parallel resistance, constant wattage, cut-to-length heating cables that can be used for freeze protection or low to medium process heating of pipe work and vessels. They can be cut to length at site and easily terminated. Suitable for use in both safe and hazardous areas. MTF and EMTF heaters are available with metallic braid, or braid and fluoropolymer outer jacket. As an alternative to the braid, a continuous metal jacket can be provided for additional mechanical protection.

Available for 100/120 and 208/240VAC. Installation of the heating cables is quick and simple and requires no special skills or tools. Termination and power connection components are all provided in convenient kits.

MICROTRACER

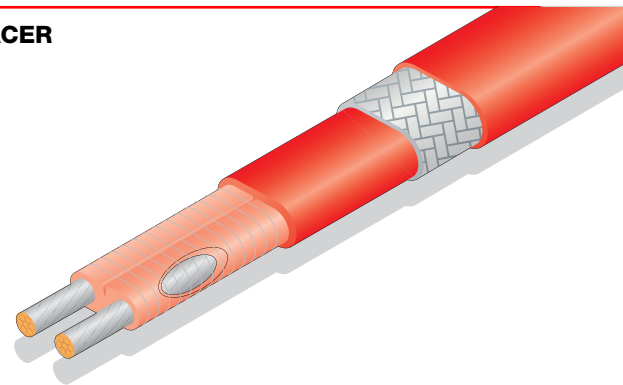

MINITRACER

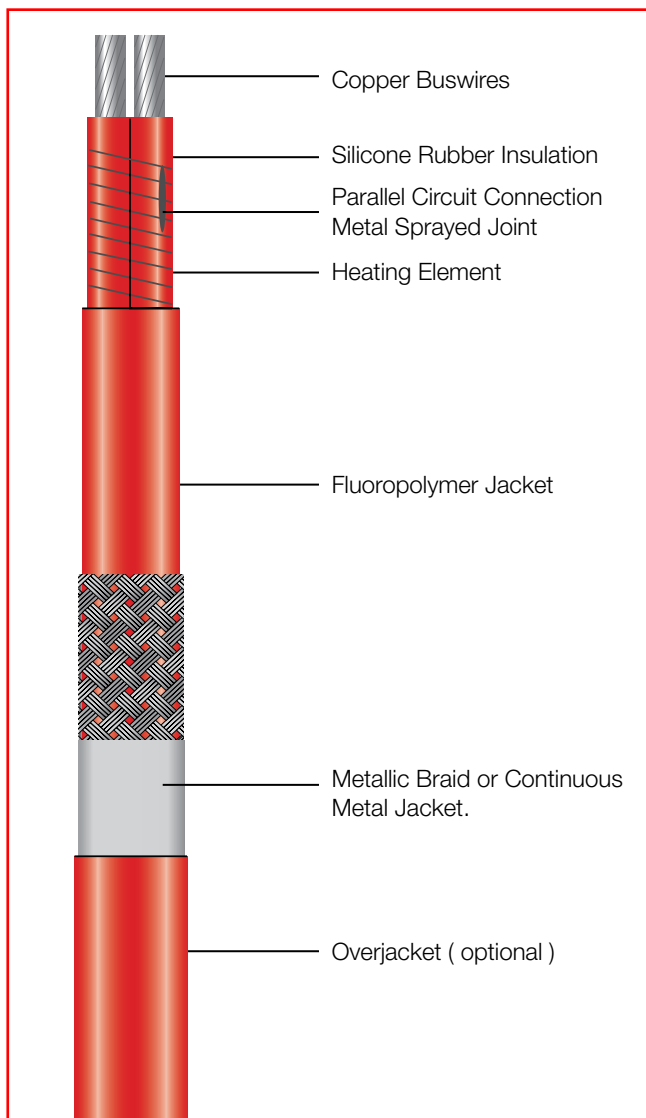
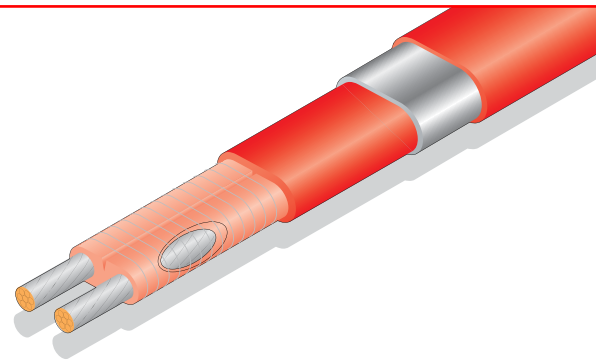

Low - Medium Temperature





Product Data - Parallel Constant Power Heaters to 200 °C

EMTF Specification Data

MAXIMUM LENGTH (m) vs. CIRCUIT BREAKER SIZE

| OUTPUT (W/m) | MAX. CIRCUIT LENGTH* | |
|-----------------|----------------------|------|
| | 115V | 230V |
| 6.5 | 82 | 164 |
| 13 | 58 | 116 |
| 23 | 44 | 87 |
| 33 | 36 | 73 |
| 50 | 30 | 59 |

* For ±10% end to end power output variation

MAXIMUM PIPE / WORKPIECE TEMPERATURES (°C)

| NOM. OUTPUT (W/m) | EMTF-C | EMTF-CF |
|-------------------------|--------|---------|
| | EMTF-A | EMTF-AF |
| 6.5 | 190 | 190 |
| 13 | 175 | 185 |
| 23 | 145 | 155 |
| 33 | 100 | 100 |
| 50 | 60 | 70 |

MTF Specification Data

MAXIMUM LENGTH (m) vs. CIRCUIT BREAKER SIZE

| OUTPUT (W/m) | MAX. CIRCUIT LENGTH* | |
|-----------------|----------------------|------|
| | 115V | 230V |
| 6.5 | 106 | 212 |
| 13 | 75 | 150 |
| 23 | 56 | 113 |
| 33 | 47 | 94 |
| 50 | 38 | 76 |

* For ±10% end to end power output variation

MAXIMUM PIPE / WORKPIECE TEMPERATURES (°C)

| CAT REF | NOM. OUTPUT (W/m) | AREA CLASSIFICATION | | | | | | |
|----------------|-------------------------|---------------------|----|-----|-----|-----|-----|------|
| | | HAZARDOUS | | | | | | |
| | | T6 | T5 | T4 | T3 | T2 | T1 | SAFE |
| MTF..C | 6.5 | 60 | 75 | 120 | 190 | 190 | 190 | 190 |
| MTF..A | 13 | 40 | 55 | 95 | 175 | 180 | 180 | 180 |
| | 23 | - | 30 | 65 | 155 | 155 | 155 | 155 |
| | 33 | - | - | 40 | 115 | 120 | 120 | 120 |
| | 50 | - | - | - | 70 | 80 | 80 | 80 |
| MTF..CF | 6.5 | 60 | 80 | 125 | 190 | 190 | 190 | 190 |
| MTF..AF | 13 | 35 | 50 | 100 | 185 | 185 | 185 | 185 |
| | 23 | - | 25 | 55 | 160 | 165 | 165 | 165 |
| | 33 | - | - | 35 | 115 | 120 | 120 | 120 |
| | 50 | - | - | - | 80 | 85 | 85 | 85 |

POWER CONVERSION FACTORS

115V HEATING CABLE

| | |
|------|-------------------------|
| 125V | Multiply output by 1.18 |
| 120V | Multiply output by 1.09 |
| 110V | Multiply output by 0.91 |
| 100V | Multiply output by 0.76 |

230V HEATING CABLE

| | |
|------|-------------------------|
| 277V | Multiply output by 1.45 |
| 240V | Multiply output by 1.09 |
| 220V | Multiply output by 0.91 |
| 208V | Multiply output by 0.82 |

For conditions other than worst case, or pipes of other materials (eg. plastic, stainless steel, etc.), consult Heat Trace Ltd. Tolerances: Voltage +10%; Resistance +10%; -0%

FULL TECHNICAL DATA SHEETS ARE AVAILABLE ON OUR WEBSITE FOR ALL PRODUCTS
www.heat-trace.com

Low - Medium Temperature



Product Data - Parallel Constant Power Heaters to 500°C

POWERHEAT - High Temperature Range Parallel Constant Power Heating Cables for exposure temperatures up to 500°C

Powerheat range PHT and AHT are parallel circuit, mineral insulated, cut-to-length, constant power heating cables. They are used for freeze protection and process heating of pipe work and vessels, where very high withstand temperatures, or where high power outputs are required. Their cut-to-length capability means they can be easily terminated at site. They are suitable for use in both safe and hazardous areas.

Powerheat cables are insulated with multiple layers of non-hygroscopic mineral materials to withstand high temperatures. PHT is available with a metallic braid, or braid and fluoropolymer outer jacket. AHT cables have an aluminium outer jacket, giving a high mechanical strength, yet still retaining flexibility. Available for 100/120 and 208/277VAC.

POWERHEAT - PHT

Withstand Temperature up to 285°C

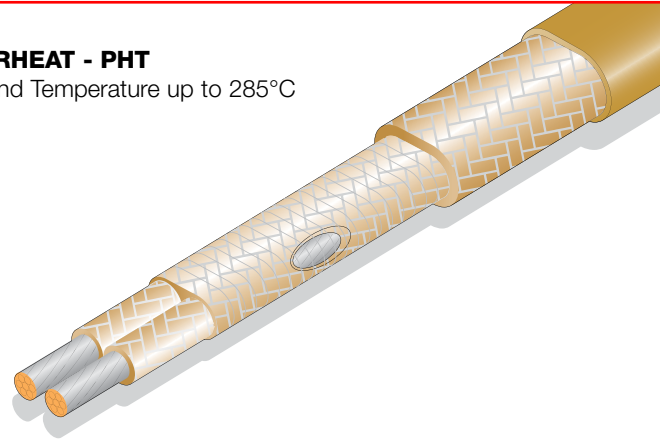

POWERHEAT - AHT

Withstand Temperature up to 500°C

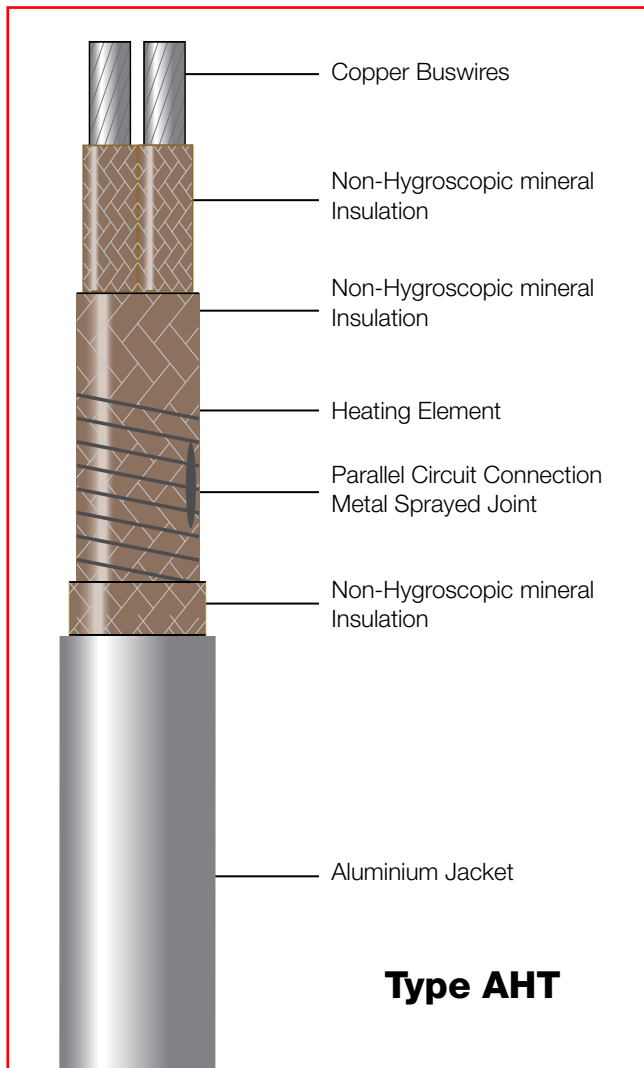
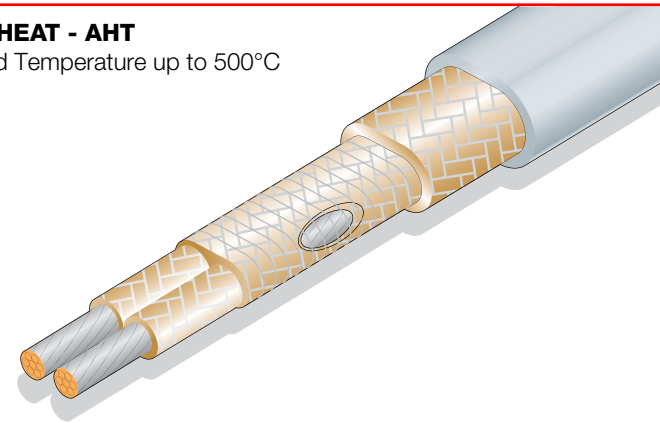

High Temperature





Product Data - Parallel Constant Power Heaters to 500 °C

PHT Specification Data

MAXIMUM LENGTH (m) vs. CIRCUIT BREAKER SIZE

| OUTPUT (W/m) | MAX. CIRCUIT LENGTH* | |
|-----------------|----------------------|------|
| | 115V | 230V |
| 10 | 79 | 152 |
| 30 | 46 | 88 |
| 50 | 35 | 68 |
| 70 | 30 | 56 |

* For ±10% end to end power output variation

MAXIMUM PIPE / WORKPIECE TEMPERATURES (°C)

| CAT REF | NOM. OUTPUT (W/m) | AREA CLASSIFICATION HAZARDOUS | | | | | | SAFE |
|------------|-------------------------|----------------------------------|----|-----|-----|-----|-----|------|
| | | T6 | T5 | T4 | T3 | T2 | T1 | |
| PHT..N | 10 | 44 | 61 | 102 | 180 | 275 | 275 | 275 |
| | 30 | - | - | 24 | 116 | 246 | 246 | 246 |
| | 50 | - | - | - | 48 | 200 | 200 | 200 |
| | 70 | - | - | - | - | 144 | 144 | 144 |
| PHT..NF | 10 | 40 | 60 | 105 | 186 | 275 | 275 | 275 |
| | 30 | - | - | 22 | 132 | 255 | 255 | 255 |
| | 50 | - | - | - | 63 | 215 | 215 | 215 |
| | 70 | - | - | - | - | 168 | 168 | 168 |

AHT Specification Data

MAXIMUM LENGTH (m) vs. CIRCUIT BREAKER SIZE

| OUTPUT (W/m) | MAX. CIRCUIT LENGTH* | |
|-----------------|----------------------|------|
| | 115V | 230V |
| 15 | 59 | 118 |
| 30 | 42 | 83 |
| 50 | 32 | 64 |
| 100 | 23 | 46 |
| 150 | 19 | 37 |

* For ±10% end to end power output variation

MAXIMUM PIPE / WORKPIECE TEMPERATURES (°C)

| CAT REF | NOM. OUTPUT (W/m) | AREA CLASSIFICATION HAZARDOUS | | | | | | SAFE |
|------------|-------------------------|----------------------------------|----|----|-----|-----|-----|------|
| | | T6 | T5 | T4 | T3 | T2 | T1 | |
| AHT | 15 | - | 36 | 71 | 160 | 289 | 350 | 350 |
| | 30 | - | 11 | 28 | 100 | 246 | 323 | 323 |
| | 50 | - | - | - | 39 | 178 | 276 | 276 |
| | 100 | - | - | - | - | 48 | 140 | 140 |
| | 150 | - | - | - | - | - | 36 | 36 |

POWER CONVERSION FACTORS

115V HEATING CABLE

| | |
|------|-------------------------|
| 125V | Multiply output by 1.18 |
| 120V | Multiply output by 1.09 |
| 110V | Multiply output by 0.91 |
| 100V | Multiply output by 0.76 |

230V HEATING CABLE

| | |
|------|-------------------------|
| 277V | Multiply output by 1.45 |
| 240V | Multiply output by 1.09 |
| 220V | Multiply output by 0.91 |
| 208V | Multiply output by 0.82 |

For conditions other than worst case, or pipes of other materials (eg. plastic, stainless steel, etc.), consult Heat Trace Ltd. Tolerances: Voltage +10%; Resistance +10%; -0%

FULL TECHNICAL DATA SHEETS ARE AVAILABLE ON OUR WEBSITE FOR ALL PRODUCTS
www.heat-trace.com

High Temperature



Product Data - Series Resistance Heaters to 125 °C

LONGLINE - Low Temperature Range **Series constant power heating cables for long pipelines. Exposure temperatures up to 125°C**

Longline HTP3F and HTP1F are series resistance, constant power heating cables used for freeze protection, or, process temperature maintenance of long pipelines where low temperatures are encountered.

HTP3F cables are used typically for pipelines up to 2km between supply points. HTP1F cables are used where there is approx 10km between supply points.

Longline series heating cables minimise the number of electrical supplies needed and so minimise supply cabling / distribution equipment costs. Circuits are often fed at the pipe ends only. All cables are available with a choice of flexible metallic braid or continuous metallic extended jacket. A further corrosion resisting overjacket in thermoplastic or fluoropolymer is optional. This style of cable is specifically designed to suit each application. The output of the heater is a function of the circuit length, the size of the conductor foils and the supply voltage.

Longline is an extremely viable option to skin effect heating for very long pipelines.

LONGLINE - HTP3F

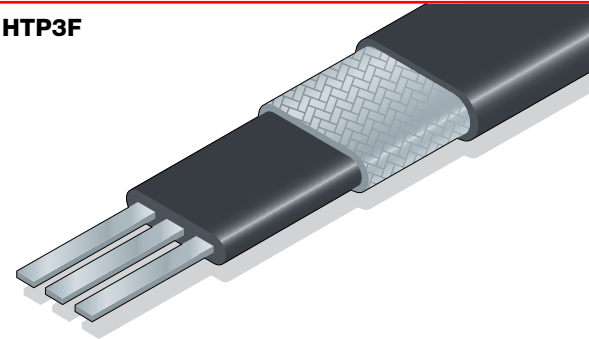

LONGLINE - HTP1F

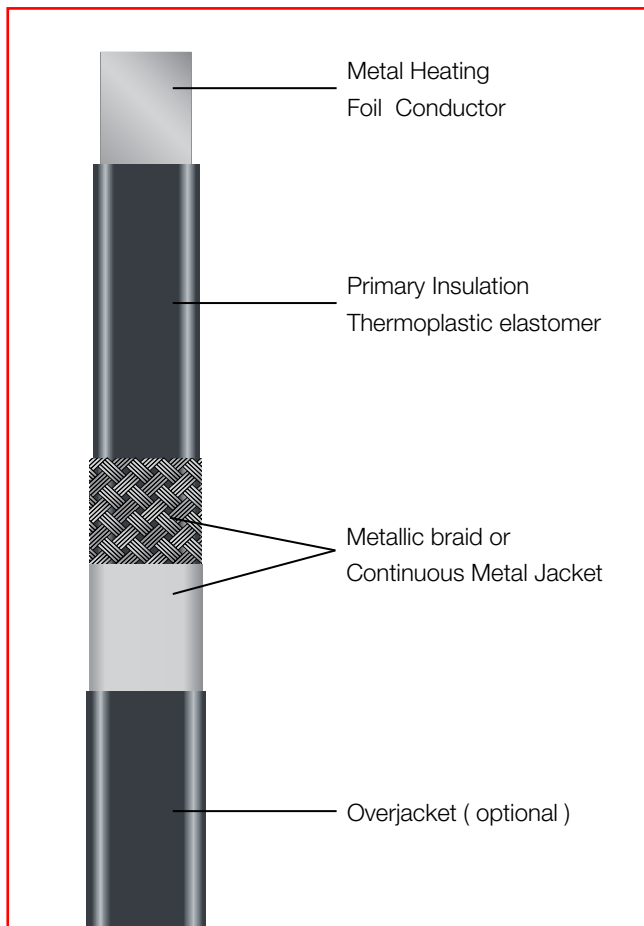
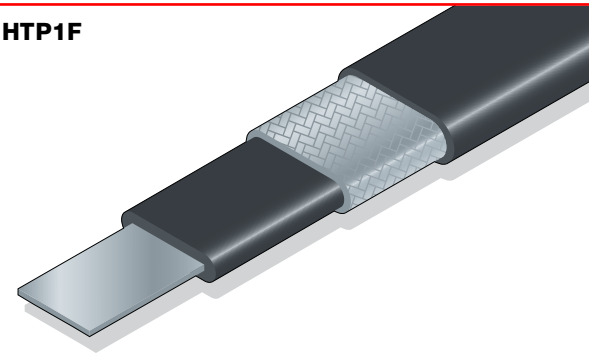

Low Temperature





Product Data - Series Resistance Heaters to 125 °C

HTP3F Specification Data

MAXIMUM PIPE / WORKPIECE TEMPERATURES (°C)

NOM. OUTPUT

| (W/m) | HTP3F-C HTP3F-A | HTP3F-CT/CF HTP3F-AT/AF |
|-------|--------------------|----------------------------|
| 10 | 109 | 100 |
| 15 | 95 | 85 |
| 23 | 80 | 70 |

For conditions other than worst case, or pipes of other materials (eg. plastic, stainless steel, etc.), consult Heat Trace Ltd.

Tolerances: Voltage +10%; Resistance +10%; -0%

HTP1F Specification Data

MAXIMUM PIPE / WORKPIECE TEMPERATURES (°C)

NOM. OUTPUT

| (W/m) | HTP1F-C HTP1F-A | HTP1F-CT/CF HTP1F-AT/AF |
|-------|--------------------|----------------------------|
| 10 | 109 | 100 |
| 15 | 95 | 85 |
| 23 | 80 | 70 |

For conditions other than worst case, or pipes of other materials (eg. plastic, stainless steel, etc.), consult Heat Trace Ltd.

Tolerances: Voltage +10%; Resistance +10%; -0%

Typical Longline applications for heating of pre-insulated pipe work with heaters in raceways.

3 Foil Longline heater

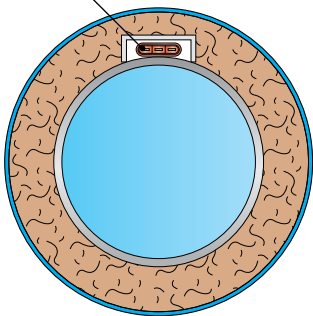

3 x Single Foil Longline heater

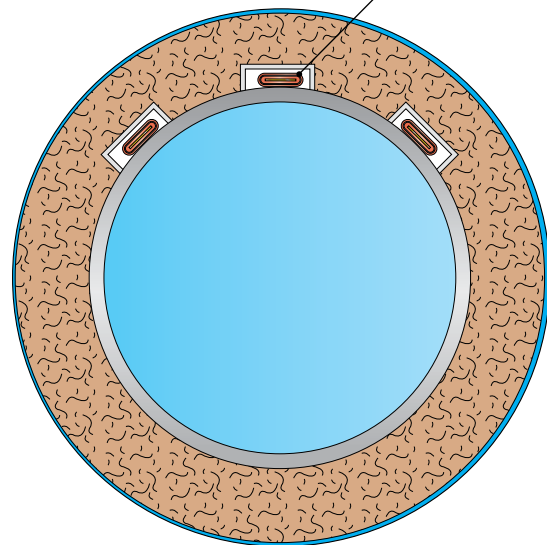

FULL TECHNICAL DATA SHEETS ARE AVAILABLE ON OUR WEBSITE FOR ALL PRODUCTS
www.heat-trace.com

Low Temperature



Product Data - Series Resistance Heaters - 230°C

LONGLINE - Medium Temperature Range **Series constant power heating cables for long pipelines. Exposure temperatures up to 230°C**

Longline HTS3F and HTS1F are series resistance, constant power heating cables with silicone insulation, used for freeze protection, or process temperature maintenance of long pipelines where medium temperatures are encountered.

HTS3F cables are used generally for long pipelines up to 2km between supply points.

HTS1F cables are typically used where there is up to, approximately 10km between supply points. Longline series heating cables minimise the number of electrical supplies needed and so minimises supply cabling / distribution equipment costs. Circuits are often fed at the pipe ends only. All cables are available with metallic braid, braid and silicone rubber jacket, or braid and fluoropolymer jacket. This style of cable is specifically designed to suit each application. The output of the heater is a function of the circuit length, the size of the conductor foils and the supply voltage. Longline is an extremely viable option to skin effect heating for very long pipelines.

LONGLINE - HTS3F

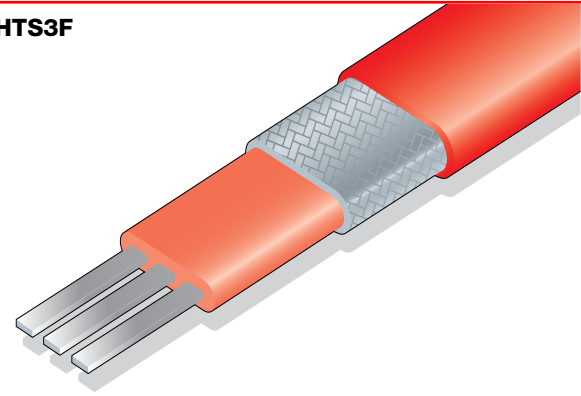

LONGLINE - HTS1F

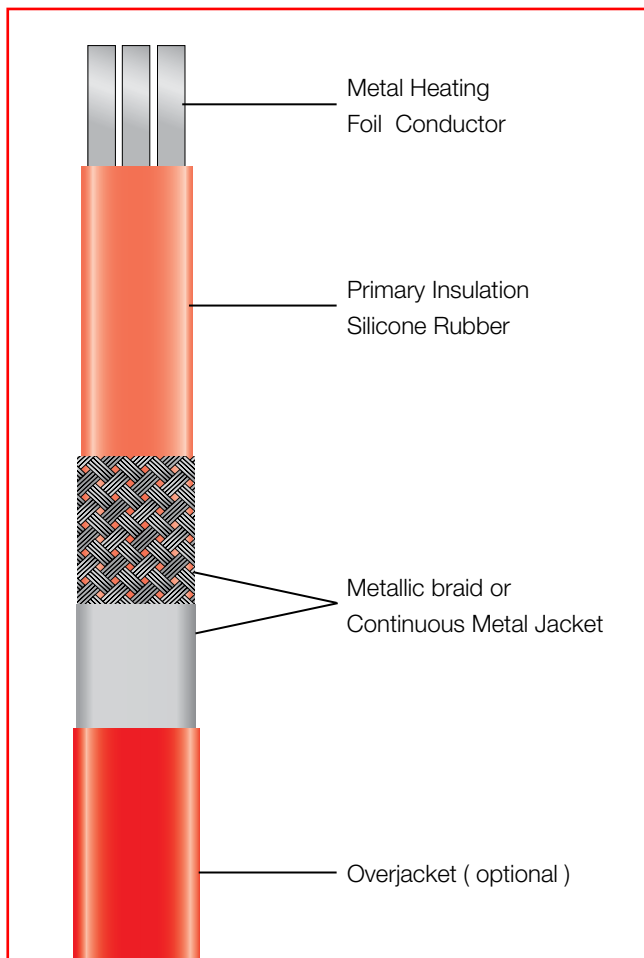
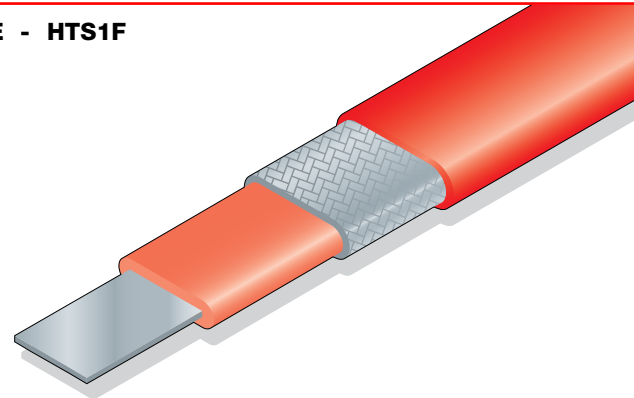

Medium Temperature





Product Data - Series Resistance Heaters - 230 °C

HTS3F Specification Data

MAXIMUM PIPE / WORKPIECE TEMPERATURES (°C)

| CAT REF | NOM. OUTPUT (W/m) | AREA CLASSIFICATION HAZARDOUS | | | | | | | SAFE |
|-----------------|-------------------|-------------------------------|----|-----|-----|-----|-----|-----|------|
| | | T6 | T5 | T4 | T3 | T2 | T1 | | |
| HTS3F-C | 10 | 48 | 66 | 107 | 181 | 218 | 218 | 218 | |
| | -A 20 | - | 32 | 75 | 158 | 191 | 191 | 191 | |
| | 30 | - | - | 41 | 133 | 164 | 164 | 164 | |
| | 40 | - | - | - | 109 | 134 | 134 | 134 | |
| | 50 | - | - | - | 76 | 97 | 97 | 97 | |
| | 60 | - | - | - | 30 | 46 | 46 | 46 | |
| HTS3F-CS | 10 | 58 | 74 | 112 | 181 | 208 | 208 | 208 | |
| | -AS 20 | 37 | 54 | 94 | 166 | 180 | 180 | 180 | |
| | 30 | - | 31 | 74 | 153 | 158 | 158 | 158 | |
| | 40 | - | - | 51 | 127 | 127 | 127 | 127 | |
| | 50 | - | - | 27 | 93 | 93 | 93 | 93 | |
| | 60 | - | - | - | - | - | - | 57 | |
| HTS3F-CF | 10 | 58 | 74 | 112 | 181 | 192 | 192 | 192 | |
| | -AF 20 | 37 | 54 | 94 | 166 | 178 | 178 | 178 | |
| | 30 | - | 31 | 74 | 153 | 165 | 165 | 165 | |
| | 40 | - | - | 51 | 127 | 127 | 127 | 127 | |
| | 50 | - | - | 27 | 93 | 93 | 93 | 93 | |
| | 60 | - | - | - | - | - | - | 57 | |

For conditions other than worst case, or pipes of other materials (eg. plastic, stainless steel, etc.), consult Heat Trace Ltd.

Tolerances: Voltage +10%; Resistance +10%; -0%

HTS1F Specification Data

MAXIMUM PIPE / WORKPIECE TEMPERATURES (°C)

| NOM. OUTPUT (W/m) | HTS1F-C | | | HTS1F-CS | | | HTS1F-CF | | |
|-------------------|---------|-----|-----|----------|-----|-----|----------|-----|-----|
| | -A | -AS | -AF | -A | -AS | -AF | -A | -AS | -AF |
| 10 | 218 | 208 | 192 | 218 | 208 | 192 | 218 | 208 | 192 |
| 20 | 191 | 180 | 178 | 191 | 180 | 178 | 191 | 180 | 178 |
| 30 | 164 | 158 | 165 | 164 | 158 | 165 | 164 | 158 | 165 |
| 40 | 134 | 127 | 127 | 134 | 127 | 127 | 134 | 127 | 127 |
| 50 | 97 | 93 | 93 | 97 | 93 | 93 | 97 | 93 | 93 |
| 60 | 46 | 57 | 57 | 46 | 57 | 57 | 46 | 57 | 57 |

For conditions other than worst case, or pipes of other materials (eg. plastic, stainless steel, etc.), consult Heat Trace Ltd.

Tolerances: Voltage +10%; Resistance +10%; -0%

FULL TECHNICAL DATA SHEETS ARE AVAILABLE ON OUR WEBSITE FOR ALL PRODUCTS
www.heat-trace.com

Medium Temperature



Termination Components

Terminations – power end

Heat Trace has three different methods for the termination of its parallel heat tracers at the power supply. All methods are available for both safe and hazardous locations:-

- Direct Entry Sealed Termination Unit (DESTU)** – This is an improved method, where the junction box is connected to the DESTU, which is mounted onto the pipe surface. The tracer passes through the DESTU into the junction box, avoiding the possibility of damage to the tracer where it exits the thermal insulation.
- Standard Method** – This uses tracer termination gland components and a junction box. To avoid the possibility of damage to the tracer where it exits from the thermal insulation, a separate lagging entry kit is required.
- AJB/D Junction Box** – a cylindrical die cast aluminium enclosure with a threaded cover. The cover incorporates a sealing ring to offer weatherproofing. The enclosure has four lugs with plain holes that are used to fix the enclosure to the mounting surface. Cable entry holes are provided for the accommodation of suitably certified cable glands or stopping plugs between the fixing lugs. External and internal earthing facilities are provided. The AJB/D Junction Box is fitted with a general purpose terminal block, with maximum permitted dissipated power inside the enclosure is 16.8 W.



DESTU



Standard Glanded Method

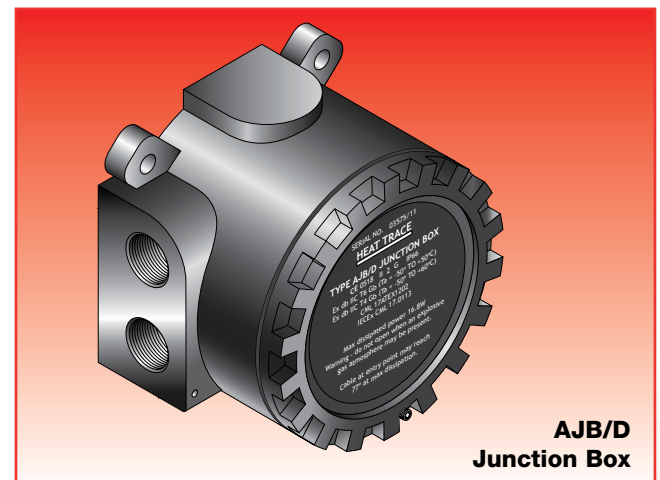

AJB/D Junction Box



Termination Components

Terminations – remote end

Heat Trace has two different methods for the termination of its parallel heat tracers at the remote end. All methods are available for both safe and hazardous locations:-

- **Moulded end seal** – The silicone rubber end seal is fixed with an adhesive. It is a simple and low cost form of sealing.
- **Heat Shrink seal** – The fitting of shrink seals require the use of a hot air gun. This may not be practical in a hazardous area.

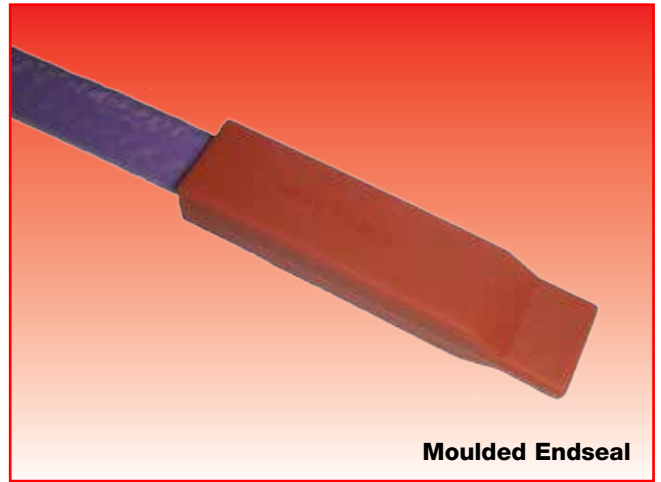

Moulded Endseal



Heatshrink Endseal

FULL TECHNICAL DATA SHEETS ARE AVAILABLE ON OUR WEBSITE FOR ALL PRODUCTS
www.heat-trace.com



TEMPERATURE CONTROL – Selection Guide

The selection of an appropriate temperature control system is dictated by its purpose or objective. This guide to selection considers two forms of control:-

- **Air-sensing**, where the air temperature is monitored and the heating load is either:
 - a) fully applied at a set temperature, as traditionally used for freeze protection installations, or,
 - b) varied with changes in ambient temperature, and hence heat losses (*called PowerMatching*).
- **Pipe or surface sensing**, where the controller sensor is located directly on the pipe or equipment surface. This method has been traditionally employed for all temperature maintenance duties.

The purpose or objective of the temperature control system may be any one or more of the following:-

1. Ensuring temperature safety

It has already been stated in Section 2 (page 12) that **temperature control to ensure temperature safety is the least favoured option** – inherently temperature safe self-regulating heaters, or a stabilised design provide greater safety. But where necessary for ensuring temperature safety, pipe or surface sensing is almost always required. Care is required to ensure that all pipes which can experience differing flow conditions are controlled independently – this may result in a large number of heating circuits.

2. Process temperature accuracy

The three levels of process temperature accuracy defined in IEC heat tracing standards, types I, II, and III, are explained in Section 3 (page 18). The approach to selecting the best control system for each type of process is described on page 47.



3. Energy efficiency

The highest levels of energy efficiency have usually required a pipe or surface sensing form of control system. This again often results in multiple heating circuits to accommodate the many permutations of flow conditions. In this case, sections of pipe having differing flow conditions need to be controlled independently.

The degree of energy efficiency is also influenced by the accuracy of the controller – electronic devices are often more accurate than mechanical types.

4. Low capital costs

The lowest capital costs will usually result from a temperature control system having the fewest number of heating circuits. This is normally achieved by an air-sensing form of temperature control system.





TEMPERATURE CONTROL – Selection Guide

Type I process control – maintaining above a minimum temperature level

It should be recognised that a Type I control system will be extremely energy wasteful. For example, a freeze protection installation controlled by an air-sensing thermostat will be 100% energised at all times when the ambient temperature falls below the thermostat setting (typically 2 or 3°C). However, the average heating requirement over the number of winter hours that the system is energised is likely to be less than 20%, i.e. **over 80% of the delivered heat will be wasted.**

Most of this waste heat can be avoided by upgrading the system to a Type II process, achieved at a very modest cost, where energy savings recover the additional cost in a very short period of time.

FOR THIS REASON, HEAT TRACE RARELY RECOMMEND A TYPE I TEMPERATURE CONTROL SYSTEM.

Type II process control – maintaining within a broad temperature band

This has traditionally been achieved by means of mechanical capillary thermostats, having their sensors located on the pipe surface.

However, in-plant piping systems are often complex, having multiple flow permutations. To control all possible permutations, a separate thermostat is required for each section of pipe having differing flow conditions. This results in many heating circuits within an expensive distribution system.

To meet the requirements of a Type II process, whilst at the same time reducing to a minimum the number of heating circuits, and hence, distribution and control panel costs, Heat Trace is able to recommend a heat tracing system where:-

- a) the tracers are spiralled to the pipes to just compensate for heat losses at the minimum ambient design temperature.
- b) the controller is Heat Trace's unique PowerMatch unit. This monitors the ambient temperature and varies the heat delivered by the tracer according to changes in ambient temperature, and hence, heat losses.

By monitoring the air rather than the pipe surface temperature, only one controller is needed for each different 'maintain' temperature. The system can be used equally for either freeze protection of process temperature maintenance.

This system may occasionally result in heat being delivered unnecessarily to some sections of pipe having flow conditions. However, the system is an excellent balance of process temperature accuracy, energy efficiency, and low capital costs.

Type III process control – maintaining within a narrow temperature band

To control all sections of a piping system within a narrow temperature band of 2°C, as required for temperature sensitive materials (e.g. chocolate), has traditionally required the use of numerous high accuracy electronic controllers, controlling several sections of pipe which may have differing flow conditions. This has necessarily been provided at a high capital cost.

However, Type III process temperature accuracy can now be achieved with the same PowerMatching control system described for Type II systems above, but with the addition of a fine tuning temperature control.

Again, the heating load delivered at any time is matched to losses according to the ambient conditions. To ensure a narrow band process accuracy, a further sensor is located on a short heated 'dummy' line incorporated into the piping system.

SUMMARY

Type I process control – maintaining above a minimum temperature level

- is very energy wasteful. Not recommended – upgrade to Type II process control

Type II process control – maintaining within a broad temperature band

- can be achieved by air-sensing PowerMatch control to provide good energy efficiency from the fewest number of heating circuits i.e. least capital cost

Type III process control – maintaining within a narrow temperature band

- can be achieved by air-sensing PowerMatch control plus fine-tune line control to provide good energy efficiency from the fewest number of heating circuits.



Type I Process Control - Maintain above a minimum point

| Type | Description | Area Location | Air or pipe/ Equipment Sensing |
|----------------------|---|--|--------------------------------|
| AT-F AIRSTAT | The AT-F AIRSTAT is a non-adjustable controller that energises the heating circuit when the sensor temperature falls to +2°C. The system then de-energises as the sensor temperature rises above +5°C. It has a MAINS ON and HEATER ON indication. | Safe Areas | Air Sensing |
| CT CAPSTAT | The CAPSTAT is a temperature adjustable ON-OFF thermostat comprising a liquid filled sensing bulb connected to an electrical switch via a capillary tube. Expansion of the liquid on rise in temperature causes the switch to open and on cooling, it closes. The CAPSTAT sensing bulb may be positioned to sense the air temperature. | Safe Areas | Air Sensing |
| CT-FL CAPSTAT | The CAPSTAT CT-FL and CT-FL/DUAL are temperature adjustable ON-OFF thermostats but for use in Zone 1 and Zone 2 hazardous areas, with enclosures suitable for Gas Groups IIA, IIB and IIC . The sensing bulb may be positioned to sense the air temperature. | Hazardous Areas Zone 1 & Zone 2 Areas | Air Sensing |

FULL TECHNICAL DATA SHEETS ARE AVAILABLE ON OUR WEBSITE FOR ALL PRODUCTS
www.heat-trace.com





Type I Process Control - Maintain above a minimum point

Switch Rating

Comments

8 amps direct switching, or via suitably rated contactor.

- AT-F AirStat is non-adjustable
- Must be located indoors
- Large blocks of heating may be switched from a single controller - fewer heating circuits are required
- Least efficient form of control



16 amps direct switching, or via suitably rated contactor.

- CT Capstat is adjustable in the range 0-40°C
- Suitable for outdoor use
- Large blocks of heating may be switched from a single controller - fewer heating circuits are required
- Least efficient form of control



16 amps direct switching, or via suitably rated contactor.

- CT-FL Capstat is adjustable in the range 0-40°C
- Suitable for outdoor use
- Large blocks of heating may be switched from a single controller - fewer heating circuits are required
- Least efficient form of control





Type II Process Control - Maintain within a broad band

| Type | Description | Area Location | Air or pipe/ Equipment Sensing |
|------------------------------------|---|--|---|
| POWERMATCH Micro+ | The POWERMATCH Micro+ is an electronic digital controller that senses changes in air temperature and then automatically adjusts the ratio of the periods in which the heaters are energised and switched off so that the heat delivered matches heat losses. | Safe Area - For hazardous areas protection is required. | Air Sensing. |
| IRE168 | The IRE168 is a single point electronic temperature controller. When connected to RTD's will energise trace heating circuits at the desired set point. | Safe Area - For Hazardous areas, appropriate Ex protection is required. (consult Heat Trace Ltd) | Air or Surface Sensing by PT100 sensor. |
| CT CT-FL CT-FL/Dual | The CAPSTAT is a temperature adjustable ON-OFF thermostat comprising a liquid filled sensing bulb connected to an electrical switch via a capillary tube. Expansion of the liquid on rise in temperature causes the switch to open and on cooling, it closes. The CAPSTAT sensing bulb may be positioned to sense the line temperature or surface temperature of a vessel. | Safe Area Hazardous Area Zones 1 & 2. | Line Sensing. |

FULL TECHNICAL DATA SHEETS ARE AVAILABLE ON OUR WEBSITE FOR ALL PRODUCTS
www.heat-trace.com





Type II Process Control - Maintain within a broad band

Switch Rating

8 amps direct switching, or via suitably rated contactor.

Comments

- Unit located in control panel
- Powermatching is significantly more efficient than conventional air sensing thermostats
- Large blocks of heating may be switched from a single controller - fewer heating circuits are required
- May be used with self regulating heating cables
- Temperature range -50 to +80°C



Internal 16A or external switching via contactors, solid state relays or Thyristor drives.

- Unit located in control panel
- DIN Rail Mounting
- Digital display
- Accurate temperature control (0.5% scale range)
- Temperature range -200 to +800°C
- Pt100 three wire sensing
- 4-20mA temperature control output



16 amps direct switching, or via suitably rated contactor.

- CT and CT-FL are adjustable thermostats with 3 temperature ranges:
Type A 0–40°C
Type B 20–110°C
Type C 20–300°C
- Suitable for outdoor use
- One thermostat is required for each pipeline - more heating circuits may be required





Type III Process Control - Maintain within a narrow band

| Type | Description | Area Location | Air or pipe/ Equipment Sensing |
|--|---|---|--|
| POWERMATCH Micro+ | <p>The POWERMATCH Micro+ is an electronic digital controller that senses changes in air temperature and then automatically adjusts the ratio of the periods in which the heaters are energised and switched off so that the heat delivered matches heat losses.</p> <p>A separate line sensing controller provides fine tune control. This sensor may be located on a “dummy” heated pipe section having no flow (dead leg).</p> | Safe Area - For hazardous areas protection is required | Air Sensing and line sensing |
| IRE168 | <p>The IRE168 is a single point electronic temperature controller. When connected to RTD's will energise trace heating circuits at the desired set point.</p> | Safe Area - For Hazardous areas, appropriate Ex protection is required (consult Heat Trace Ltd) | Air or Surface Sensing by PT100 sensor |
| IRE8 | <p>The IRE8 is a user friendly multi-channel (4 or 8) electronic PID temperature controller. Control parameters for each output can be preset independently and are automatically set by auto-tuning. For monitoring purposes, 3 different alarm outputs are provided. Each channel is connected to air or pipe sensing PT100 RTD's.</p> | Safe Area - For Hazardous areas, appropriate Ex protection is required (consult Heat Trace Ltd) | Air and Surface Sensing by PT100 sensor. |
| GUARDIAN ENERGY MANAGEMENT SYSTEM | <p>Guardian is an 8 channel, computer assisted energy management, control and auditing system for large / critical heat tracing installations. It may be provided as a stand alone system or integrated into the plant's SCADA or DCS system. Details of the auditing / monitoring facilities are provided on page 55.</p> | Safe Area - For hazardous areas protection is required | Line sensing |

FULL TECHNICAL DATA SHEETS ARE AVAILABLE ON OUR WEBSITE FOR ALL PRODUCTS
www.heat-trace.com





Type III Process Control - Maintain within a narrow band

| Switch Rating | Comments | |
|---|---|---|
| <p>16 amps direct switching, or via suitably rated contactor.</p> | <ul style="list-style-type: none"> ● Unit located in control panel ● Powermatching is significantly more efficient than conventional air sensing thermostats. Type III accuracy is provided by the additional line sensing control ● Large blocks of heating may be switched from a single controller - fewer heating circuits are required ● May be used with self regulating heating cables ● Temperature range -50 to +80°C |  |
| <p>Internal 16A or external switching via contactors, solid state relays or Thyristor drives.</p> | <ul style="list-style-type: none"> ● Unit located in control panel ● DIN Rail Mounting ● Digital display ● Accurate temperature control (0.5% scale range) ● Temperature range -200 to +800°C ● Pt100 three wire sensing ● 4-20mA temperature control output |  |
| <p>Internal 3A or external switching via contactors, solid state relays or Thyristor drives.</p> | <ul style="list-style-type: none"> ● Unit located in control panel ● Fascia Mounted ● Multi Digital display ● Full navigation facilities ● Accurate temperature control (0.5% scale range) ● 3 alarm outputs ● Temperature range -199 to +600°C ● Pt100 three wire sensing ● Output: relay or SSR; (optional: TRIAC, 0-20mA or 4-20mA) ● RS485, RS422 & RS232 communication |  |
| <p>Internal 5A relays or suitably rated, contactors or solid state relays.</p> | <ul style="list-style-type: none"> ● Unit located in control panel, DIN rail mounted ● Controls and monitors up to 8 individual heating circuits per Guardian ● Precise temperature control ● Full time surveillance of heating system integrity ● Pt100 three wire sensing ● Alarm Functions ● Output by Relay or SSR ● Local LCD Monitoring panel with full navigation (Optional) ● RS485 Modbus Communication to remote PC with "Guardian Consultant" package ● Trend analysis, Performance and Alarm Reports (Optional) |  |





Circuit Monitoring

Circuit Monitoring of smaller heat tracing installations

Where critical to the process, circuit health monitoring is provided by Heat Trace's Watchdog system. This is located in the control and monitoring panel and periodically energises the circuits to ensure that they are operating correctly. In the event of damage to a tracer, an alarm is raised to enable corrective action. This can often take place before the pipeline has time to cool to an unacceptable level.

Watchdog is available as a single or 5 circuit device.





Circuit Monitoring

Circuit Monitoring of large heat tracing installations

Large heat tracing installations, when critical to the process, may be monitored by the 5 circuit Watchdog monitoring devices shown opposite.

However, when the Guardian computer assisted energy management control and auditing system is selected, this provides the user with the ultimate in monitoring facilities. This SCADA type control has all the benefits of electronic control, complemented by the addition of computerisation. This development allows two-way communication between the control system and a remotely located computer. Additionally, all control parameters, collected data system drawings and system information can be stored and retrieved, and full visual indication is available.

Heating circuits are continuously monitored for correct function and temperature. Circuit currents and supply voltage may be measured and used by the software package to calculate the individual circuit power and running costs. Alarms are raised in the event of any non-compliance. A data link to the main process computer is also available, with the option of an internet protocol module for providing communications over TCP/IP and HTTP for web pages, or emailing of alarm messages.

Control and monitoring parameters may be inputted either remotely or locally as required. System parameters are stored in the computer and in each Guardian controller. This gives ultimate reliability, as all parameters are capable of being downloaded to replacement units.

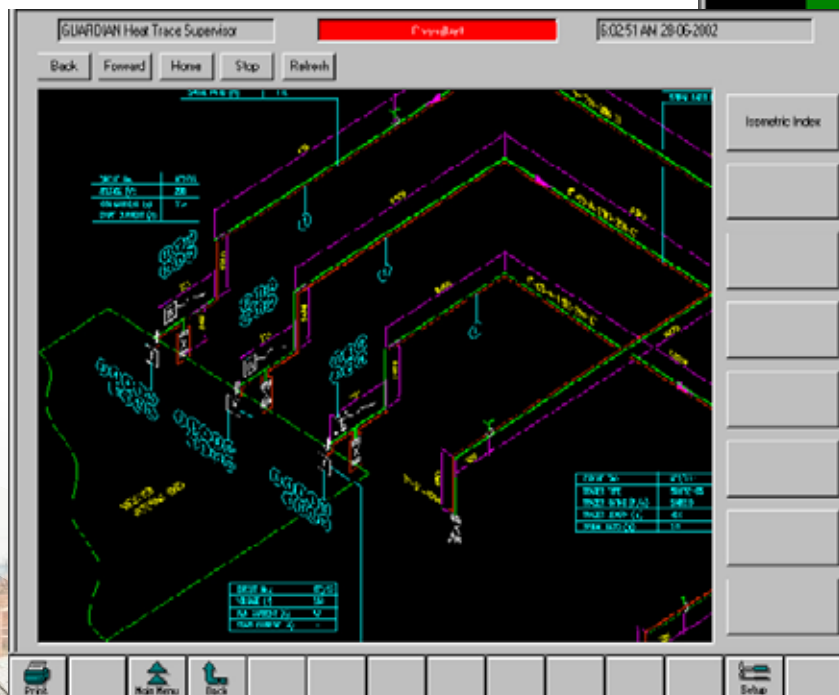
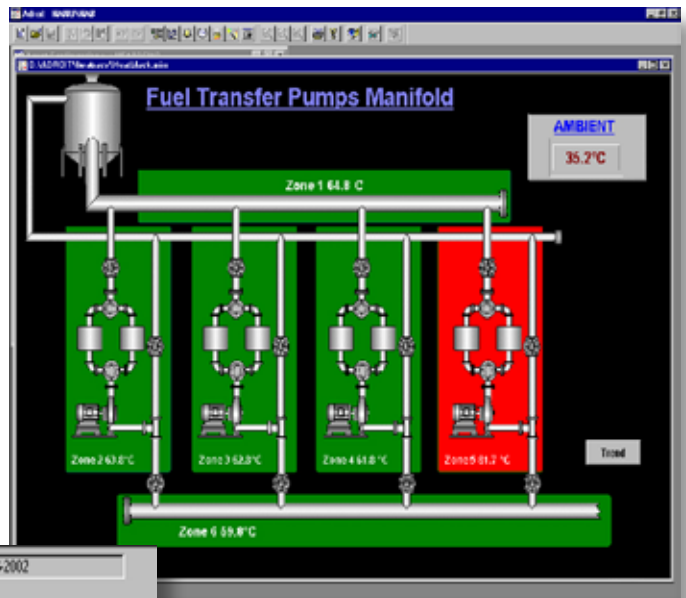



Pre-installation

It is essential that the heat tracing system is correctly installed, tested, commissioned, and maintained. Heat Trace will provide comprehensive instructions for the installation of the system equipment. However, we would recommend that the following points are taken into consideration:-

Personnel

Persons involved in the installation and testing of electric heat tracing systems should be suitably trained in all special techniques required. Installation should be carried out under the supervision of a qualified electrician who has undergone supplementary training in electric heat tracing systems. Where systems are for use in explosive gas atmospheres, additional qualifications apply, such as knowledge of system certifications.

Equipment verification

Prior to installation, the design data used for the heat tracing design should be verified and the as-built piping and other equipment should be checked against the enquiry drawings.

The installation of the heat tracing system should be co-ordinated with the piping, thermal insulation and instrument disciplines.

Pre-installation testing

Pre-installation tests shall be performed and documented on a checklist similar to that below. This also helps verify the heat tracing design.

- a) Heat tracers shall be visually checked for damage. Continuity and insulation checks should be made and insulation resistance measured from heat tracer conductors to the metallic braid or sheath, with a minimum 500 Vdc test voltage. The measured insulation resistance shall not be less than 20 M.Ohms.
- b) Controls shall be tested to ensure correct calibration of, for example, set points, operating temperature range and span.
- c) Control panels shall include documentation certifying that all wiring, layout and functions are correct and have been tested. A general inspection of the panels shall confirm that no damage has occurred in transit.





Pre-installation checks

Table 1 - Pre-installation checks

| Items to be checked | Remarks |
|--|--|
| 1 Is the work piece fully erected and tested and all temporary supports removed? Is the surface to be heated free from sharp edges, weld spatter and rough surfaces? | Any welding or pressure testing after the installation of a heat tracer could damage the device |
| 2 Is the surface upon which the heat tracer is to be applied normal steel or non-metallic? | If the surface is of polished stainless steel, very thin-walled pipe or non-metallic of any kind, special precautions may be necessary |
| 3 Do the items to be heated correspond in size, position, etc.. with the design? | It is sometimes difficult to be sure that the correct pipe is being heated. A suitable line numbering system may be of assistance |
| 4 Has it been specified that metallic foil be installed before the application of the heat tracer? | This may be used to aid heat distribution |
| 5 Has it been specified that metallic foil be installed after the application of the heat tracer? | This may be used to prevent insulation from surrounding the heat tracer or to aid heat distribution |
| 6 Can flow of product under normal or abnormal conditions reach temperatures greater than those that the heat tracer can withstand? | This would normally be covered in the design stage; however, further discussion with staff at the plant may show that incorrect or out-of-date information has been used |
| 7 Is the heat tracing system documentation (working drawings, designs, and instructions) available? | No change should be contemplated without reviewing the heat tracing system documentation, as careful calculations are necessary to ensure safe operation |
| 8 Can pipes or surfaces expand and contract so as to cause stress on any part of the heat tracing installation? | In this case precautions are necessary to avoid damage |
| 9 Can sensors of temperature controllers be affected by external influences? | An adjacent heating circuit could affect the sensor |
| 10 Is the heat tracer to be spiralled or zigzagged onto the work piece, according to the design? | Check design loading per unit length of pipe (or surface area) to determine if spiral or zigzag application is necessary |
| 11 Are cold leads, when fitted, suitable for contact with the heated surface? | If the cold lead is to be buried under the insulation, it has to be able to withstand the temperature |
| 12 Is the pipe work hung from a pipe rack? | In this case, special precautions are required to ensure the weatherproofing of the insulation at points of suspension |
| 13 Does pipe work have its full complement of supports? | The addition of intermediate supports at a later stage could damage the heating system |
| 14 Are sample lines/bleed lines, etc.. at the plant but not on drawings? | These could obstruct or prevent the fitting of the heat tracer, and a review of the heat tracing system documentation may be necessary |
| 15 Are other parameters used in the design of the equipment as specified by the design documentation? | More or less lengths of trace heater may be required than was called for in the design. This may require for redesign of the circuit. |
| 16 Are the heat tracers, controllers, junction boxes, switches, cable glands, etc., suitable for the environmental conditions and are they protected as necessary against corrosion and the ingress of liquids and particulate matter? | If the trace heater design does not meet the intended application, the circuit must be redesigned and the system documentation must be updated. |





Installation of heat tracers - General

Heat tracers should be attached to clean piping and equipment in accordance with the instructions. Care should be taken at flanges and fittings to position heaters so as to avoid damage. Check that the heater assembly can accommodate movement and vibration.

The installer should allow the appropriate amount of heater to compensate for additional heat losses from pipeline fittings, as allocated by the *Evolution* design software.

A heat tracer should be kept in as intimate a contact as possible to the heated surface. Where close contact is not possible, such as on valves, a heat-conductive covering of metal foil may be used.

It is recommended that the heat tracer is not folded, twisted, or allowed to overlap, cross or touch itself. Attention should be given to the minimum bending radius.

Where heat tracers cross possible sources of leaks, for example, flanges, they should be positioned to minimize contact with the leaking medium.

Only genuine Heat Trace components may be used or else the system certification will be invalidated.

● Straight tracing runs on pipe

Single straight traced runs are usually positioned at the underside of the pipe, fixed at 300mm centres, using only the correct Heat Trace fixing tape.

Multiple straight heat tracers should be equally spaced around the circumference of the pipe. Extra lengths of heat tracer will have been provided for in the design to compensate for the additional heat losses at pipe fittings, valves etc..

● Spiral tracing runs on pipe

The pipe and equipment should be marked at the design spiral pitch. Then apply the heat tracer in a uniform spiral from the power supply point maintaining slight tension in the tracer as it is applied. Fix at no more than 2 metre centres using only the correct Heat Trace fixing tape.

Spiral tracing runs should be applied in such a way that valves, etc., can be easily removed or replaced.





Installation of heat tracers - General

● Connections and terminations

It is essential that all heat tracers are terminated correctly with approved components to Heat Trace's instructions.

Longline heat tracers intended for site termination should be checked to ensure that the installed lengths correspond to the design length and loading.

Connection of the heat tracer to the power supply should be such as to prevent physical damage, and positioned to prevent the ingress of water.

Heat tracing circuits are connected into Heat Trace junction boxes specifically designed for connection of the tracer. The boxes provide appropriate protection and certification. Junction box lids should not be left open at any time.

The metallic braid or sheath of the heat tracer must be bonded to the earthing system to provide for an effective ground path.

Tracer end seals must be securely fitted to Heat Trace's instructions and protected to avoid mechanical damage and ingress of water.



● Marking and tagging

After installation, all the circuits must be properly marked / tagged, as follows:-

- a) Branch circuit breaker
- b) Monitor and alarm apparatus
- c) Heat tracer power connection
- d) Circuit number and set point for each temperature controller

Marking shall be carried out for each heat tracing circuit, on the respective junction box.

● Post installation testing

The pre-installation insulation resistance test described above shall be repeated on all heat tracer circuits after installation, using a minimum 500Vdc megger. The measured insulation resistance shall not be less than 20 M.Ohms.

Continuity and resistance checks shall be made for each circuit and the installed tracer load confirmed with the design load.

The type, length and electrical data of each heat tracer shall be noted for inclusion in the final documentation. The connection points shall be recorded for entry in the piping and instrumentation diagrams.





Installation of control and monitoring equipment

General

The installer is usually responsible for fixing the control and monitoring and distribution panels. These will, as a minimum, provide over-current and earth-leakage protection as well as means of isolation. Some form of temperature control or limitation is usually provided to ensure safe temperatures or for energy efficiency purposes.

Verification of equipment suitability

The supplied controllers, thermostats, sensors, and related devices shall be checked to match those specified in the design with regard to the service temperature, the IP rating, and, for hazardous areas, certification. The certification of heat tracing systems may prescribe the use of specific components. In these cases it is mandatory to use only parts specified by Heat Trace.

Temperature controller and monitoring devices

The sensors of the temperature controllers may be air sensing or applied directly to the pipe. The sensors are usually resistance temperature detectors, or capillary tube thermostats.

Water and corrosive vapour intrusion can cause failure of temperature controllers. The cover or lid of a controller housing should always be closed after installation, except when required for access.





Installation of control and monitoring equipment

General sensor installation

The sensor for surface temperature control is installed onto the surface of the pipe or equipment in accordance with the designer's instructions in a position that will provide a temperature representative of the overall circuit. The sensor should be positioned so as not to be influenced by the temperature of the heat tracer, or other factors such as heat sinks and solar gain.

Ambient temperature-sensing controllers should be sited in the most exposed position for the installation.

Line sensors should be strapped in good thermal contact with the pipe or equipment and protected so that thermal insulation cannot be trapped between the sensor and the heated surface. Care should be taken not to damage the capillary tube, or RTD leads, or to distort the sensor and thereby cause calibration error.

Care should be taken to ensure that the capillary tube, or RTD leads emerge from the thermal insulation in a manner that will not allow the ingress of moisture.

Sensor installation for temperature limiting device

When a system has to employ a temperature controller in order to ensure temperature safety, then clearly the positioning of the sensor is critical to the safety of the plant.

The sensor for the temperature limiting controller is installed onto the surface of the pipe or equipment in a position that will provide a temperature representative of the overall circuit. In order to assure that the safety temperature controller can accurately react to the maximum heat tracer surface temperature, particular attention must be paid to the location, method of attachment and set point. This method of sensor installation is based on the known relationship between the equipment temperature and the heater sheath temperature at a given power output.

It is important that the controller is set such that the heater sheath temperature does not exceed the limiting temperature under worst-case conditions (e.g. voltage +10%, tracer at upper limit of manufacturing power tolerance, heater out of contact with the pipe/equipment, high ambient, no external convection).



Warning

Some heat tracing companies offer low cost series resistance heaters of minimal mechanical strength that are designed for use with voltage regulating devices. These require the sensor of the over-temperature controller to be fitted to the surface of the heater itself. However, this is a practice that Heat Trace Ltd. does not recommend because:-

- It will rarely be known to be sensing the hottest point of the heater (which is likely to be where the heater is out of contact with the equipment) and
- When the sensor is removed, for example during maintenance work, it cannot be guaranteed to be returned to the hottest part of the heater

The practice of fitting a temperature sensor to the heater to ensure temperature safety is dangerous!





Installation of thermal insulation system

Precautions must be taken to protect tracers from mechanical damage and moisture intrusion after they have been installed and prior to the application of thermal insulation. The installation supervisor shall coordinate with the thermal insulation contractor, so that the thermal insulation is applied as soon as possible after the installation and testing of heat tracers.

It should be confirmed that the thermal insulation to be installed is of the size, specification and thickness used for the design of the heat tracing system.

When a tracer is installed onto the surface of a pipe, it's effective diameter is increased. The thermal insulation is usually provided in pre-formed sections. Thus a small gap may occur due to the addition of the tracer. In this case, 'filler' segments should be installed to ensure full insulation. Note that, if over-sized insulation is used (i.e. the next pipe size up), then heat loss calculations must be based on the over-sized pipe value.

The thermal insulation installation crew should be experienced /trained in fitting insulation over tracers, particularly with a view to avoiding mechanical damage, which is most likely when cutting and forming sheet metal cladding around flanges and other line equipment.

Warning labels must be fixed to the cladding at 6m intervals advising that electric tracers are installed beneath the thermal insulation and fitted to the cladding over each valve or item of equipment that may require periodic maintenance.

Field circuit insulation resistance test

The test procedure described above shall be conducted on all heat tracer circuits after lagging, with the requirement that the measured insulation resistance shall not be less than $20M\Omega$

Visual inspection

Carry out a visual inspection of the thermally insulated system to ensure that:

1. moisture cannot penetrate the insulation
2. screws used for fastening cladding are short enough to preclude any possibility of damage to tracers or temperature sensors.
3. entry cut-outs in the cladding for heat tracers, temperature sensors, etc., are dimensioned so as to render contact impossible.
4. cladding joints and thermal insulation entries are properly sealed with an elastic, non-hardening sealant resistant to chemical attack.

Documentation

The thermal insulation material and its thickness shall be documented.





Installation of electrical power

The branch circuit wiring of each heat tracing circuit requires an over-current protective device. The size and type of distribution wiring, and the ratings of the branch circuit protective devices is based on heater start-up currents and their duration at the minimum temperature that the heat tracing device may experience.

An earth fault protective device RCD shall also be provided. Check that protective devices are sized correctly to the rated current and, where applicable, have appropriate certificates.



A FULL INSTALLATION, TESTING AND MAINTENANCE MANUAL IS AVAILABLE ON OUR WEBSITE
www.heat-trace.com



Commissioning & Documentation

Functional check and final documentation

The heat tracing system(s) shall be commissioned after the thermal insulation has been installed and the electrical distribution is completed. The heat tracer commissioning record given in Table 2 shall be completed and retained.

- Close all branch circuits and verify proper current. A temporary bypass may be required for the temperature control device.
- Verify that monitor or alarm circuits are operable. A bypass may be required at field contacts.
- Fill out the heat tracer commissioning record (Table 2) for each circuit. This shall clearly document all testing and commissioning data.
- Record the electrical insulation resistance values for each measurement taken.
- Record the applied voltage and resulting current after five minutes of energization, and pipe temperature if required.
- Verify that the alarm and monitor components operate as intended.
- Verify that the calibration check at the temperature controller setpoint has been performed and the controller has been set at this value.

Final documentation

Adequate and uniform documentation of the electric heat tracing circuits is an essential precondition for economical maintenance of this equipment. This is especially important to facilitate rapid troubleshooting in the event of circuit problems. It also provides the basis for simpler, faster and less costly handling of any desired modifications and expansions by a specialist for electric heat tracing systems.

The documentation of each heating circuit of a heat tracing system shall include the following elements:

Design and testing documentation:

- Table of contents
- Piping diagram showing the heat tracing circuits and the location of power points, connections, splices, tees, end terminations, and temperature sensors for control and limitation
- For vessels: layout of the heat tracing
- Pipe and thermal insulation list
- Individual circuit length of heat tracers
- Calculation and dimensioning data
- Material list
- Heat tracer installation instructions
- Heater cabling plan
- Description of and installation instructions for temperature sensors
- Heater commissioning record (Table 2)
- Temperature profile measurement
- Installation certificate

Circuit diagrams:

- Wiring and circuit diagram
- Terminal connection diagrams, switchgear with parts list
- Installation instructions

Other:

- Technical descriptions and instruction manuals for the individual pieces of equipment
- Functional diagram as agreed to with the design engineer
- Certificates or declarations of conformity from a certification agency for explosive gas atmosphere equipment, as required

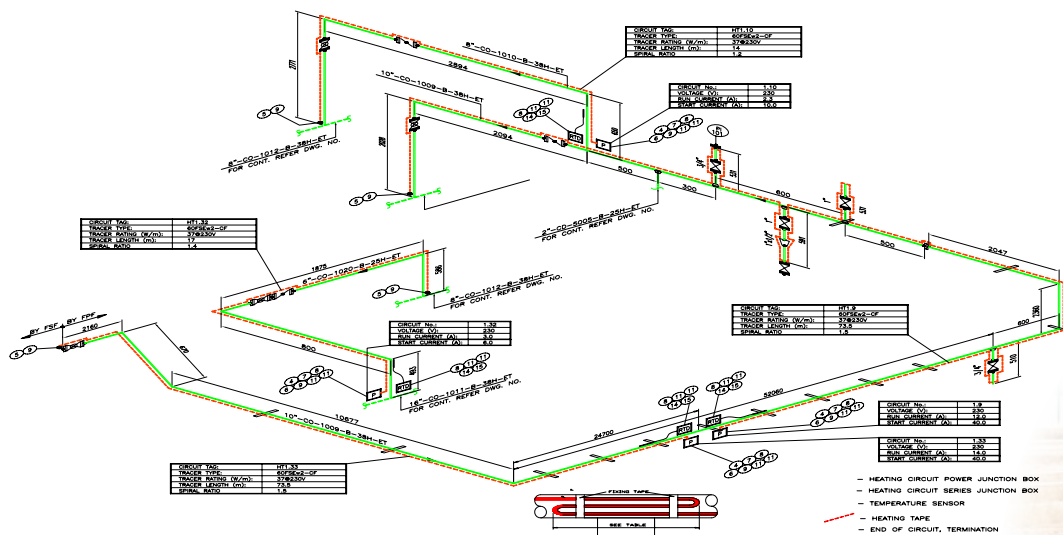



Commissioning & Documentation

Table 2 - Heat tracer commissioning record

| | | | | | | | |
|---|-------|------------------------|--------------|--|---------------------|-----------------------------|---------|
| Location | | System | | Project number | | Reference drawing(s) | |
| Line number | | Heat Tracer number | | Area classification | | Temperature classification | |
| Panel number | | Location | | Circuit number | | Circuit amp/voltage | |
| Heat Tracer manufacturer | | Heat Tracer model | | Heat Tracer wattage unit length/voltage rating | | | |
| Verify certification marking: | | | | | | | |
| HEAT TRACER INFORMATION: | | | | | | | |
| Heat Tracer total design length | | | | Heat Tracer total installed length | | | |
| Thermal insulation type | | | | Thermal insulation thickness | | | |
| Workpiece maintain temperature | | | | Maximum workpiece temperature | | | |
| HEAT TRACER TESTING: (data from heat tracer installation record) | | | | | | | |
| Electrical resistance (continuity) test, in ohms | | | | | | | |
| Electrical insulation resistance test, in Megohms | | | | | | | |
| Test ambient temperature | | | | | | | |
| PERFORMANCE DATA: | | Volts a.c. | | Current in amperes | | | |
| | Panel | Field | Single-phase | Three-phase | | | |
| | | | Line | A phase | B phase | C phase | Neutral |
| Start-up | | | | | | | |
| After 5 min | | | | | | | |
| After 4 h | | | | | | | |
| Ambient temperature at time of test | | | | | | | |
| Pipe temperature at beginning of test | | | | After 4 h | | | |
| Calculated watts per unit length (V x A/m) | | | | After 4 h | | | |
| TEMPERATURE CONTROL: type | | | | | | | |
| Heat Tracer controller | | Ambient sensing | | Workpiece sensing | | Temperature setpoint | |
| High limit controller | | Type | | Location | | Temperature setpoint | |
| Heating controls calibrated | | | | | | | |
| Heating controls operation verified | | | | | | | |
| ALARMS/MONITORING: type | | | | | | | |
| Temperature | | High setting | | Low setting | | Operation verified | |
| Heat Tracer current | | High setting | | Low setting | | Operation verified | |
| Residual current | | | | Setting | | Operation verified | |
| Loss of voltage | | | | | | Operation verified | |
| Other | | | | | | Operation verified | |
| RCD PROTECTION: type | | | | | | | |
| Setting | | Measured current | | | Tested in operation | | |
| Performed by: | | | | Company | | Date | |
| Witnessed by: | | | | Company | | Date | |
| Accepted by: | | | | Company | | Date | |
| Approved by: | | | | Company | | Date | |



Maintenance

General

It is recommended that the maintenance schedule given in Table 3 should be undertaken each year. All maintenance activities should be recorded in a maintenance log (such as that shown in Table 3) and retained in the system documentation.

Fault location

Specialised methods of fault location are necessary to find faults in electric heat tracing systems covered by thermal insulation and metallic cladding, and advice should be sought from the electric heat tracing system designer. Most commonly, faults are caused by mechanical damage, corrosion, overheating or ingress of moisture.

Fault rectification

When the fault has been located, the defective component should be replaced or repaired. Those parts of the installation that have been disturbed should be checked in accordance with Table 2 and recorded in accordance with Table 3.





Maintenance

Table 3 – Maintenance schedule and log record

| | | | | | |
|--|----------|------------------------------------|---------|----------------------|--|
| Location system | | System | | Reference drawing(s) | |
| CIRCUIT INFORMATION | | | | | |
| Heat tracer number | | Circuit length | | Breaker panel no. | |
| Power connection | | Design voltage | | Breaker pole(s) no. | |
| Tee connection | | Residual current protection (type) | | | |
| Splice connection | | Residual current trip setting | | | |
| Process control type I, II or III | | Heating controller type | | | |
| Circuit Monitoring | YES / NO | | | | |
| VISUAL | | | | | |
| Panel no. | | Circuit no. | | | |
| | | Date | | | |
| | | Initial | | | |
| Thermal insulation | | | | | |
| Damaged insulation/ lagging | | | | | |
| Water seal acceptable | | | | | |
| Insulation/lagging missing | | | | | |
| Presence of moisture | | | | | |
| Heating system components | | | | | |
| Enclosures, boxes sealed | | | | | |
| Presence of moisture | | | | | |
| Signs of corrosion | | | | | |
| Heat tracer lead discolouration | | | | | |
| Heating and/or high limit controller | | | | | |
| Operating properly | | | | | |
| Controller set point | | | | | |
| ELECTRICAL | | | | | |
| Insulation resistance testing (bypass controller if necessary) | | | | | |
| Test voltage | | | | | |
| Megger value, MΩ | | | | | |
| Heat tracer supply voltage | | | | | |
| Value at power source | | | | | |
| Value at field connection | | | | | |
| Heat tracer circuit current reading | | | | | |
| Amps reading at 2 to 5 min. | | | | | |
| Amps reading after 15 min. | | | | | |
| Ground-fault current | | | | | |
| Comments and actions | | | | | |
| Performed by: | | | Company | | |
| Approved by: | | | Company | | |
| | | | Date | | |
| | | | Date | | |



A Handbook of
Industrial
Electric Heat Tracing



Heat Trace Limited, Mere's Edge, Chester Road, Helsby, Frodsham, Cheshire, WA6 0DJ, England.
Tel: +44 (0)1928 726 451 www.heat-trace.com